



Driveline and Chassis Technology

ZF Transmissions with Mechatronics

Hans-Peter Bach, Director Service (hans-peter.bach@zf.com)
ZF Getriebe GmbH, Business Unit Automatic Transmissions





Topics

- **Business unit „Automatic transmission“**
- **The 6HP gearbox-family**
- **Hints for the repair shop**
 - ◆ **General hints**
 - ◆ **gearbox change**
 - ◆ **change of a mechatronic**
 - ◆ **change of a oil pan and filter**
 - ◆ **changing or adding oil**

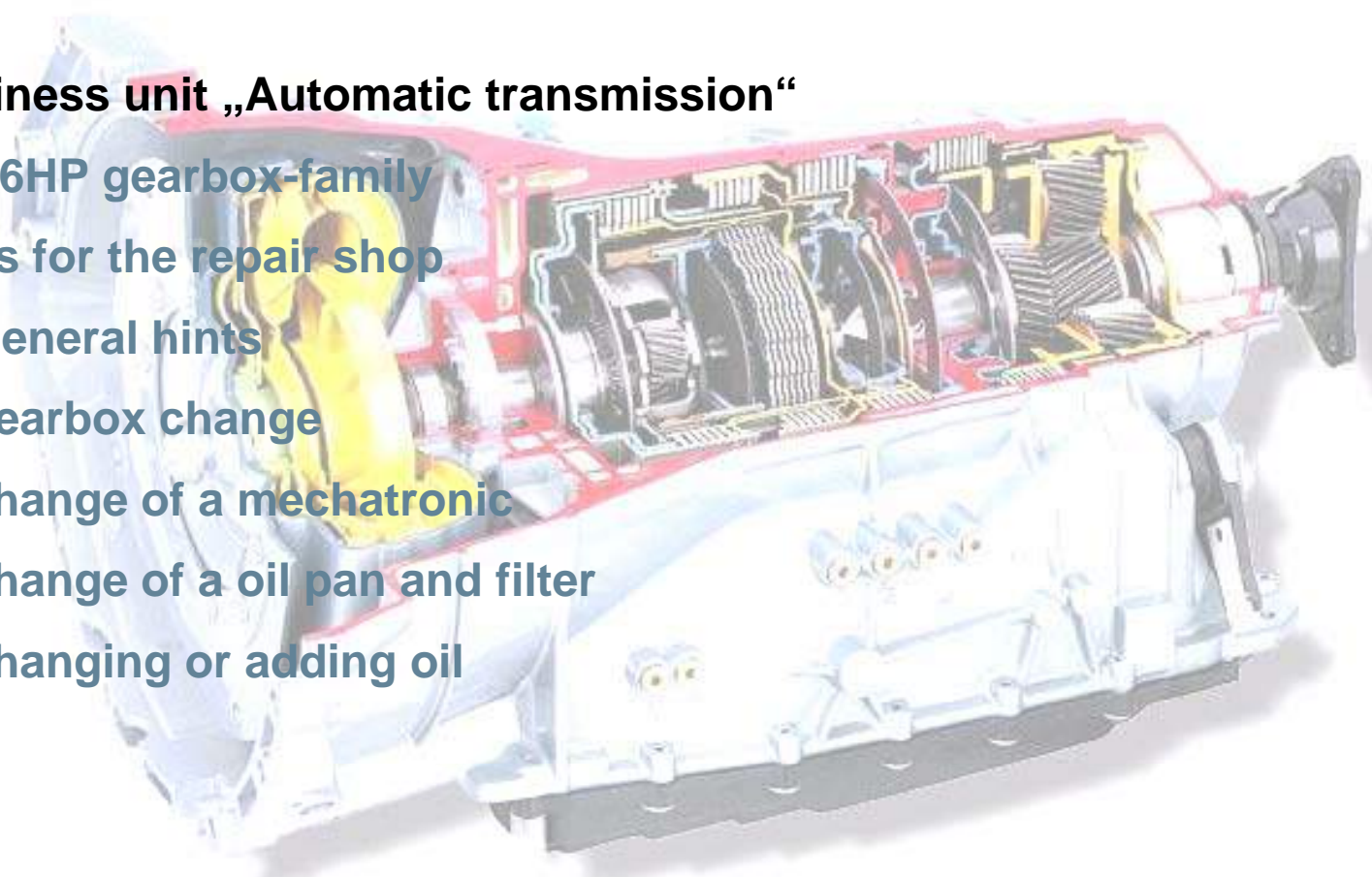



P-Division ZF Getriebe GmbH Car Driveline Technology Locations



Saarbrücken (AT) 1973
Germany



Saarbrücken-Völklingen, Plant 4 (DVZ / Logistic) Germany



Brandenburg (MT/DT) 1991
Germany



Kressbronn (R&D) 1969
Germany



Friedrichshafen (R&D) 1988
Germany



Shanghai (AT)** 2006
China

** Joint Venture with SAIC.



Topics

- Business unit „Automatic transmission“
- The 6HP gearbox-family
- Hints for the repair shop
 - ◆ General hints
 - ◆ gearbox change
 - ◆ change of a mechatronic
 - ◆ change of a oil pan and filter
 - ◆ changing or adding oil

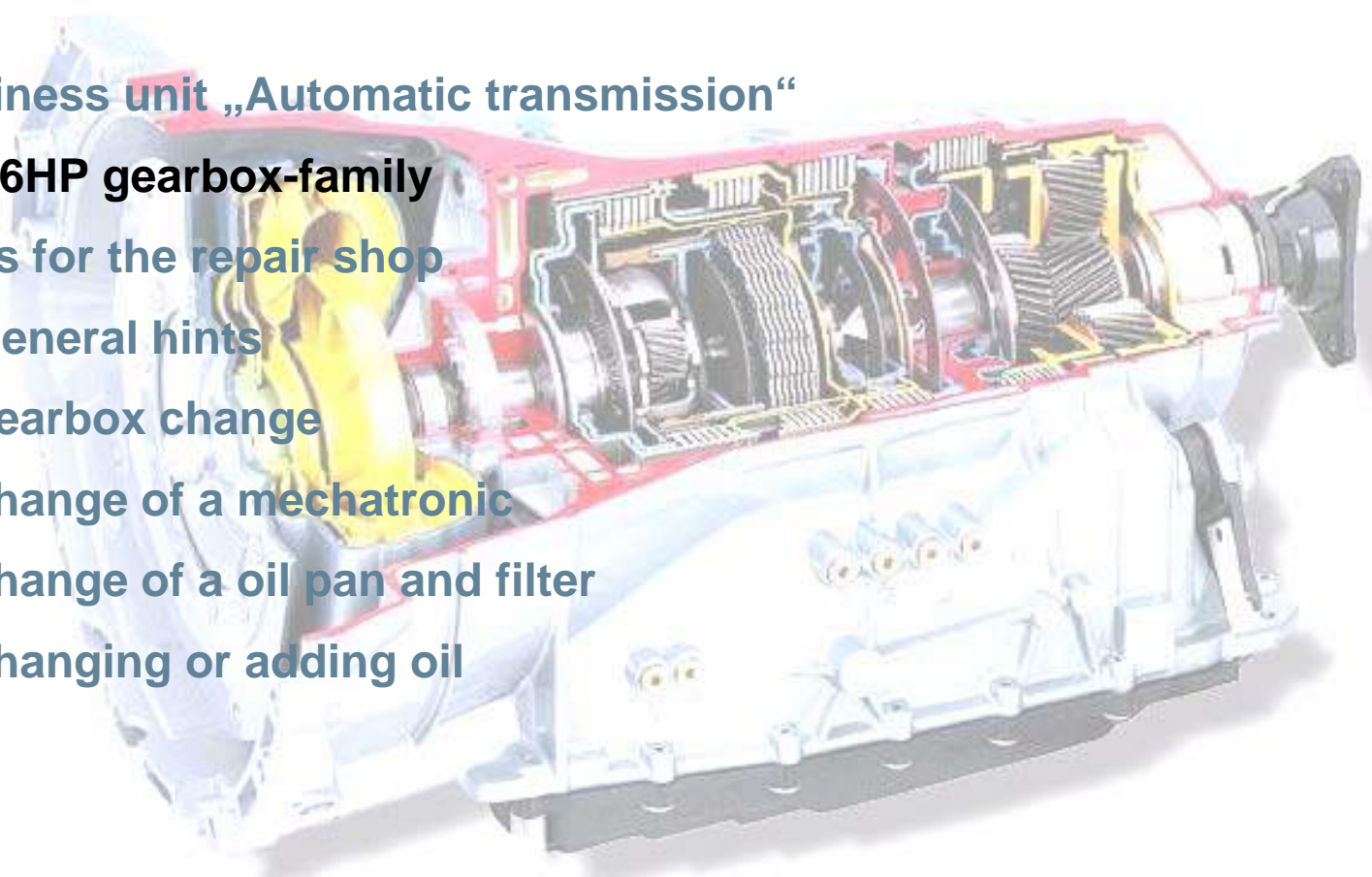



Product History of the ZF 6-speed Automatic Transmission



1999	IAA in Frankfurt: First Prototype of a fully-automatic six-speed transmission
2001	World premiere: Start of volume production for the first automatic 6-speed transmission worldwide, the 6HP26; compared to automatic 5-speed transmissions: weight savings of 13% and 30% less components
2005	Presentation of hybrid system (basis: 6HP26) at the IAA in Frankfurt
2006	Introduction of 2 nd generation of automatic 6-speed transmissions with another 3-6% in fuel savings and even faster shift times (partly below the driver's limit of perception)



Cutaway drawing 6HP26

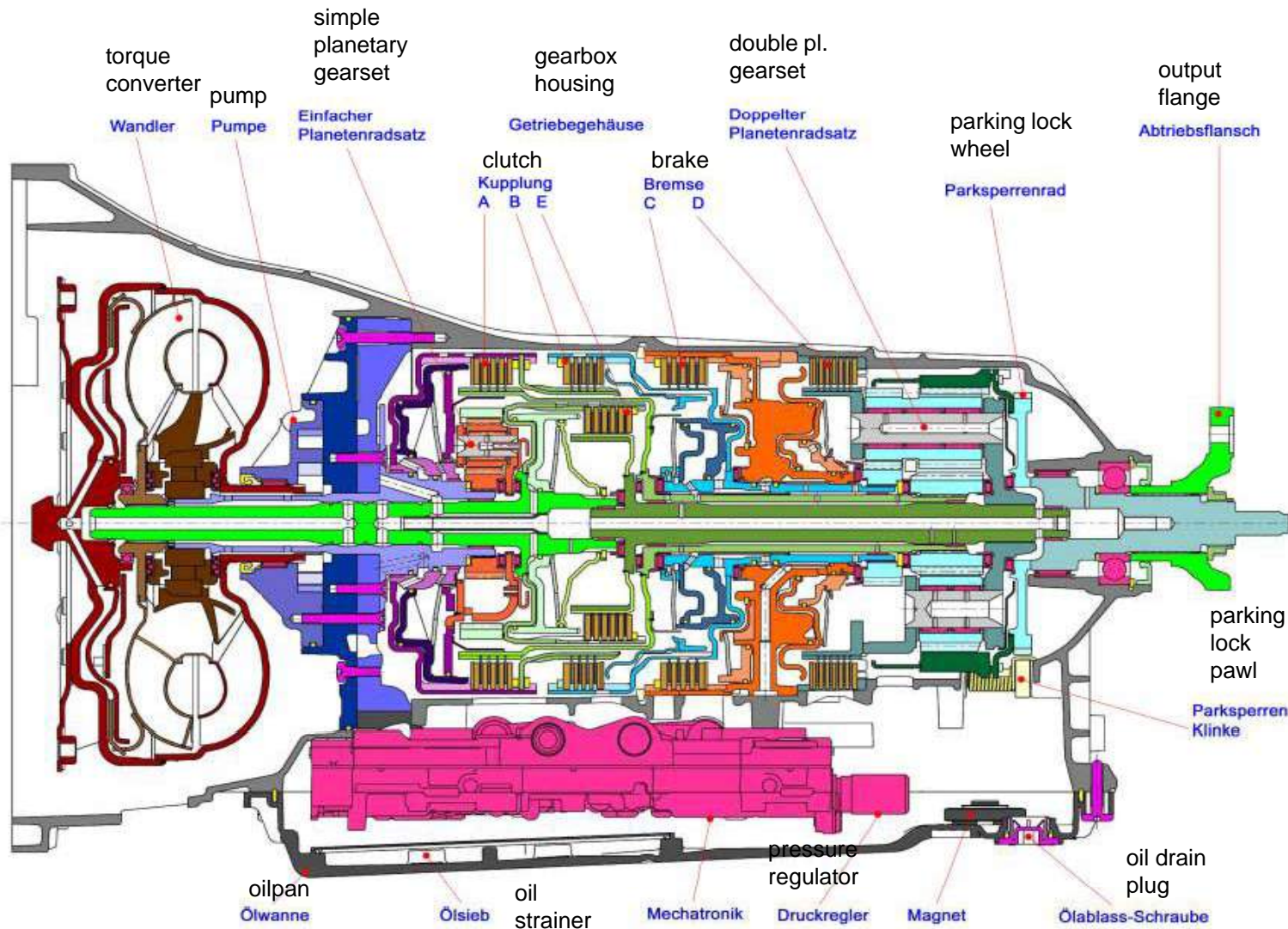



6HP... Product Family Improvements of the 2nd Generation

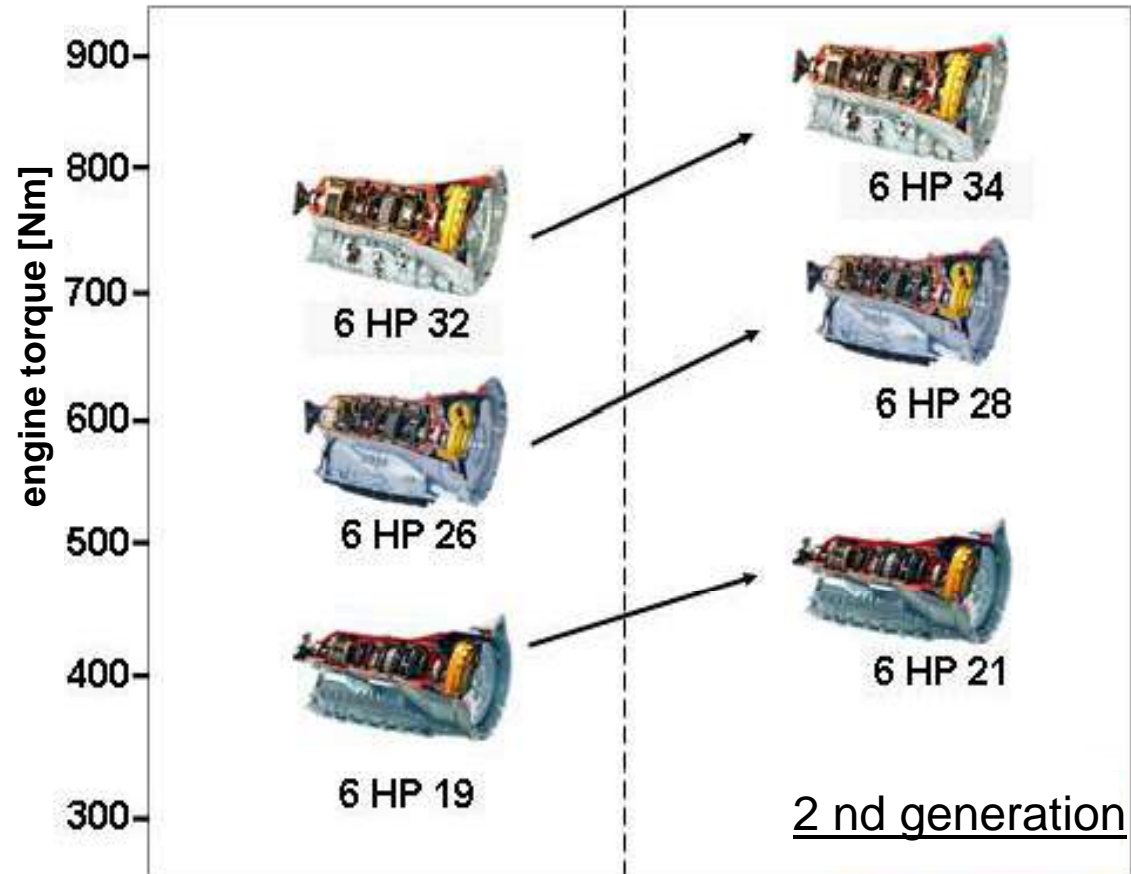



Second Generation of 6-speed Automatic Transmissions

The individual, automatic driving pleasure

Second generation of the 6HP:
Efficiency and increased performance for the leading 6-speed automatic transmission.

- Considerable contribution to CO₂ and/or fuel economy
- Increased power-to-weight ratio
- Optimized shift dynamics and improved subjective driving impression
- Shift times below the driver's limit of perception

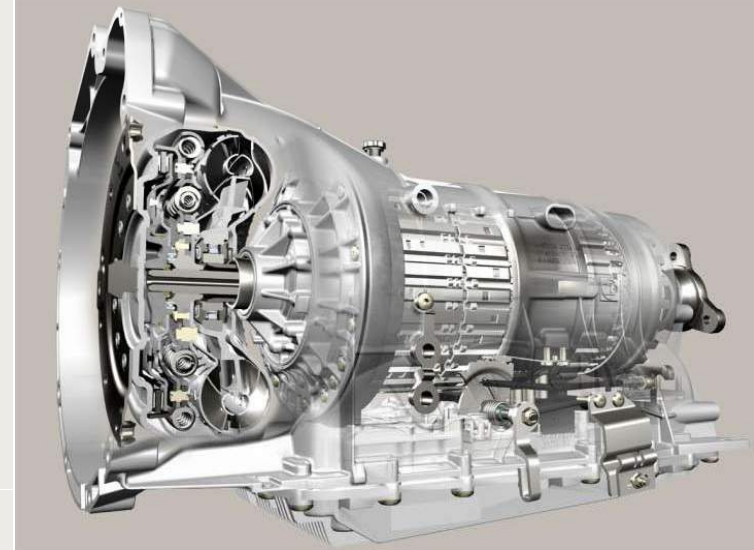



Reduction of CO₂ and Fuel Consumption

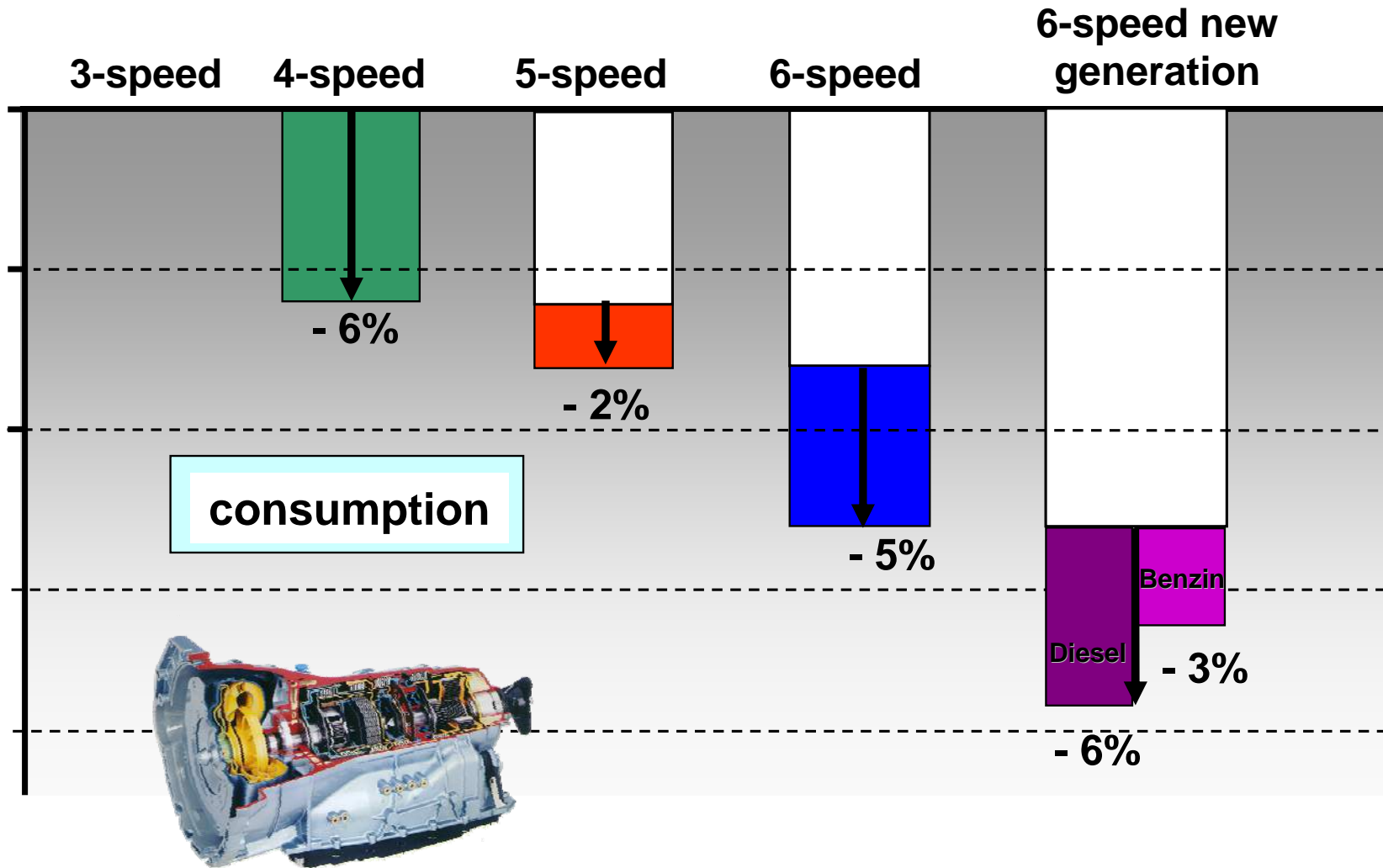



Further development of shift dynamics (2nd Generation of 6-speed transmissions)

- Shift dynamic is one of the most significant characteristics of the vehicle performance
- The direct shift gearbox has set new standards in shifting dynamics

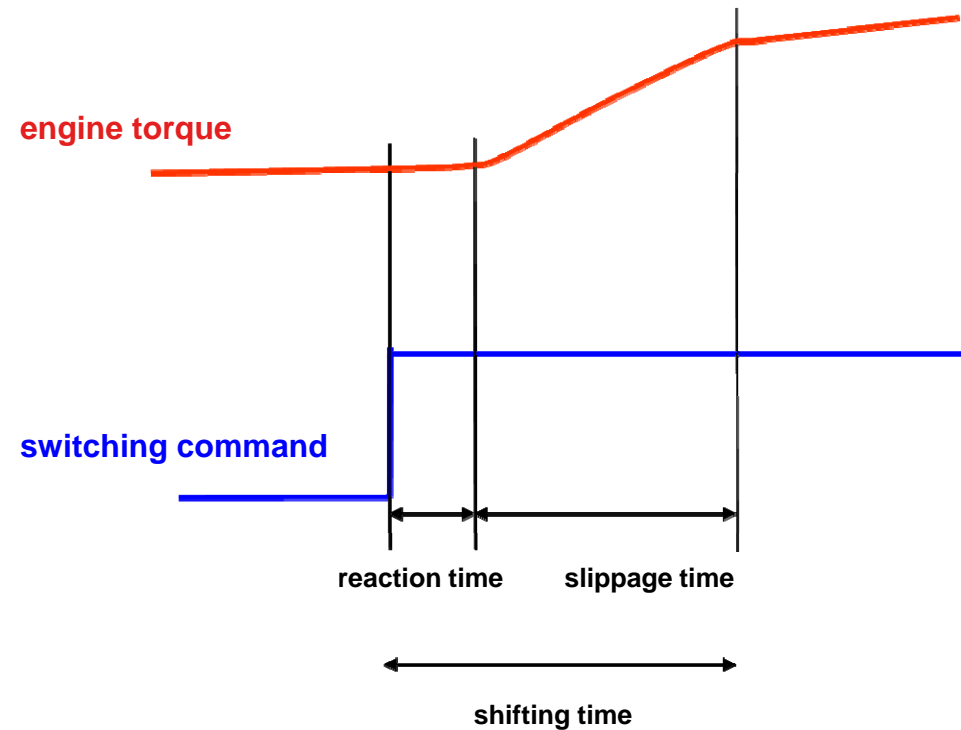



Improvement shift dynamics

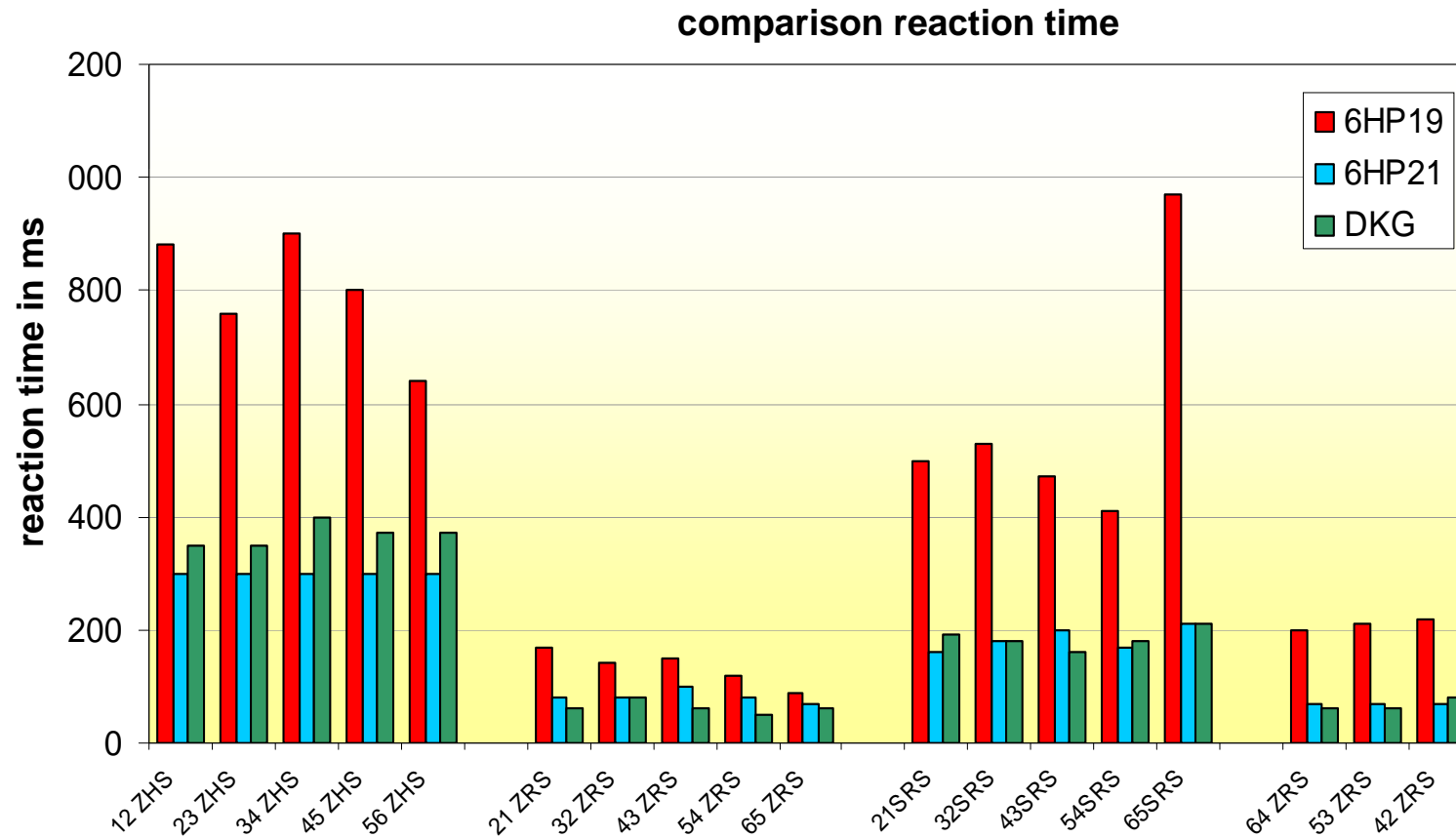



Topics

- Business unit „Automatic transmission“
- The 6HP gearbox-family
- Hints for the repair shop
 - ◆ General hints
 - ◆ gearbox change
 - ◆ change of a mechatronic
 - ◆ change of a oil pan and filter
 - ◆ changing or adding oil

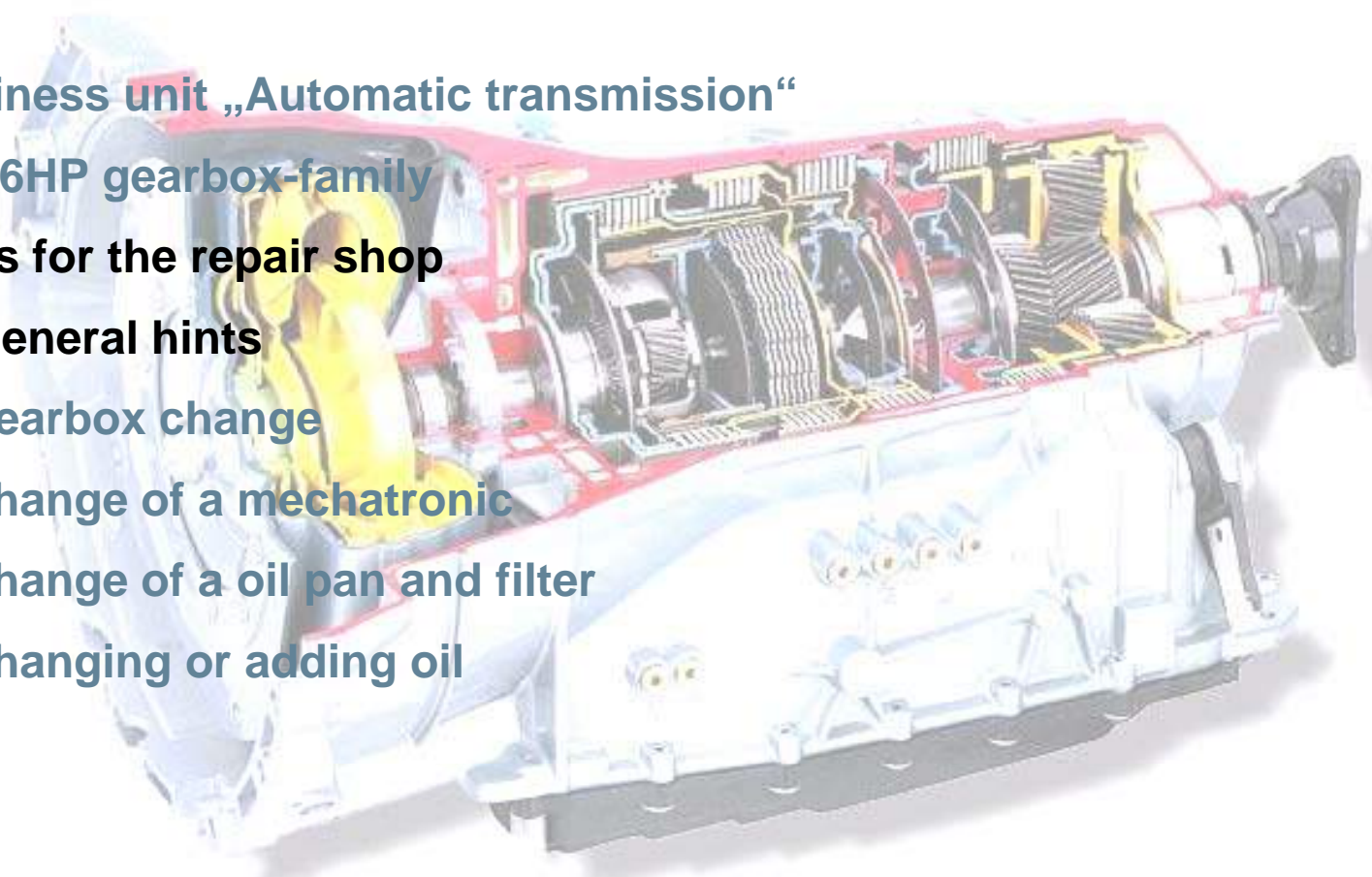



Towing a vehicle

- Towing of a vehicle only on its driven wheels at **no more than 70 km/h** road speed and a **maximum distance of 500 kilometres**
- Selector lever in **N** (neutral)
- If the above mentioned **speed** and **distance limits** are **not respected**, the **automatic transmission** will be severely **damaged!**



Topics

- Business unit „Automatic transmission“
- The 6HP gearbox-family
- Hints for the repair shop
 - ◆ General hints
 - ◆ gearbox change
 - ◆ change of a mechatronic
 - ◆ change of a oil pan and filter
 - ◆ changing or adding oil

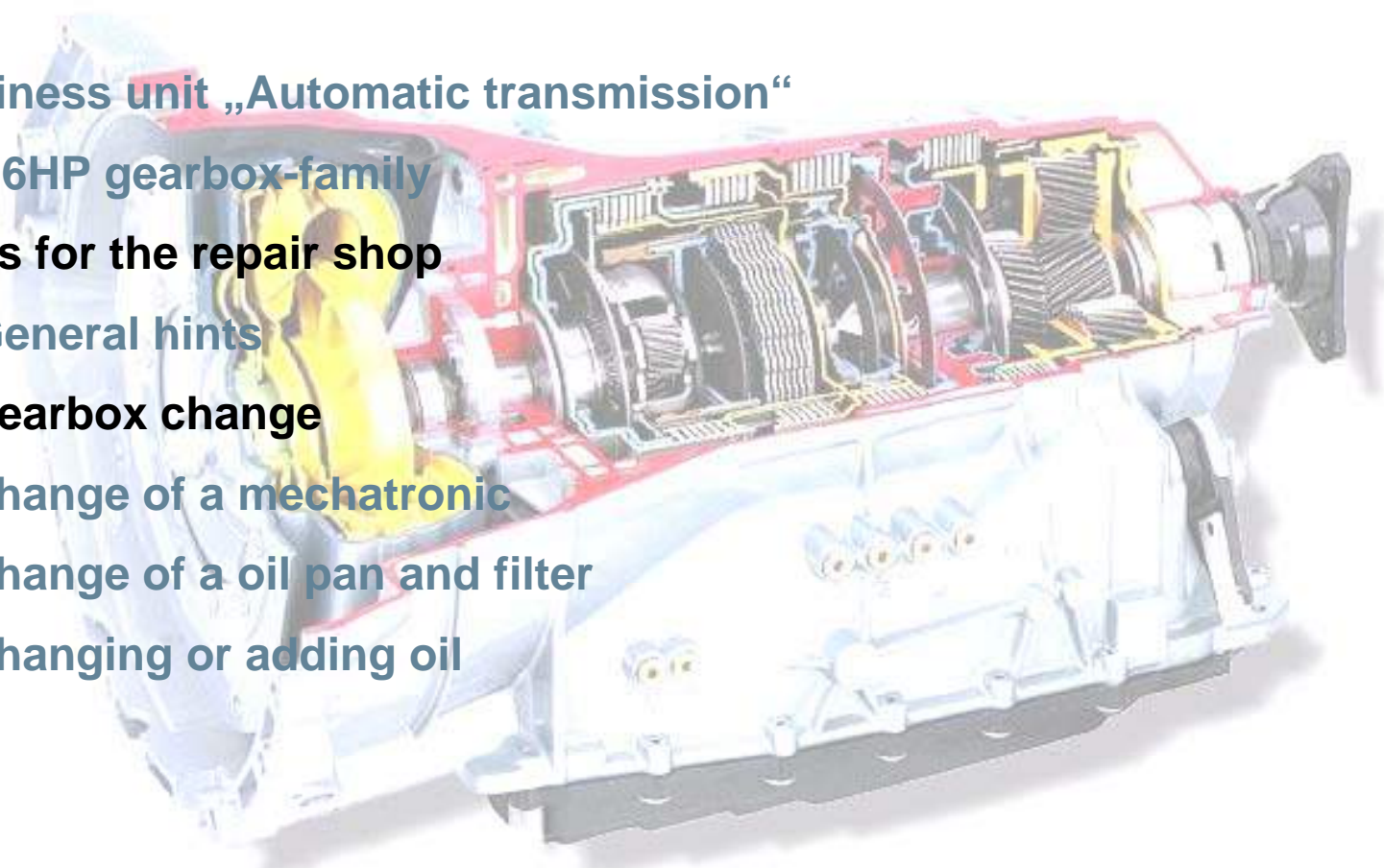



Transmission ready to be installed into the vehicle

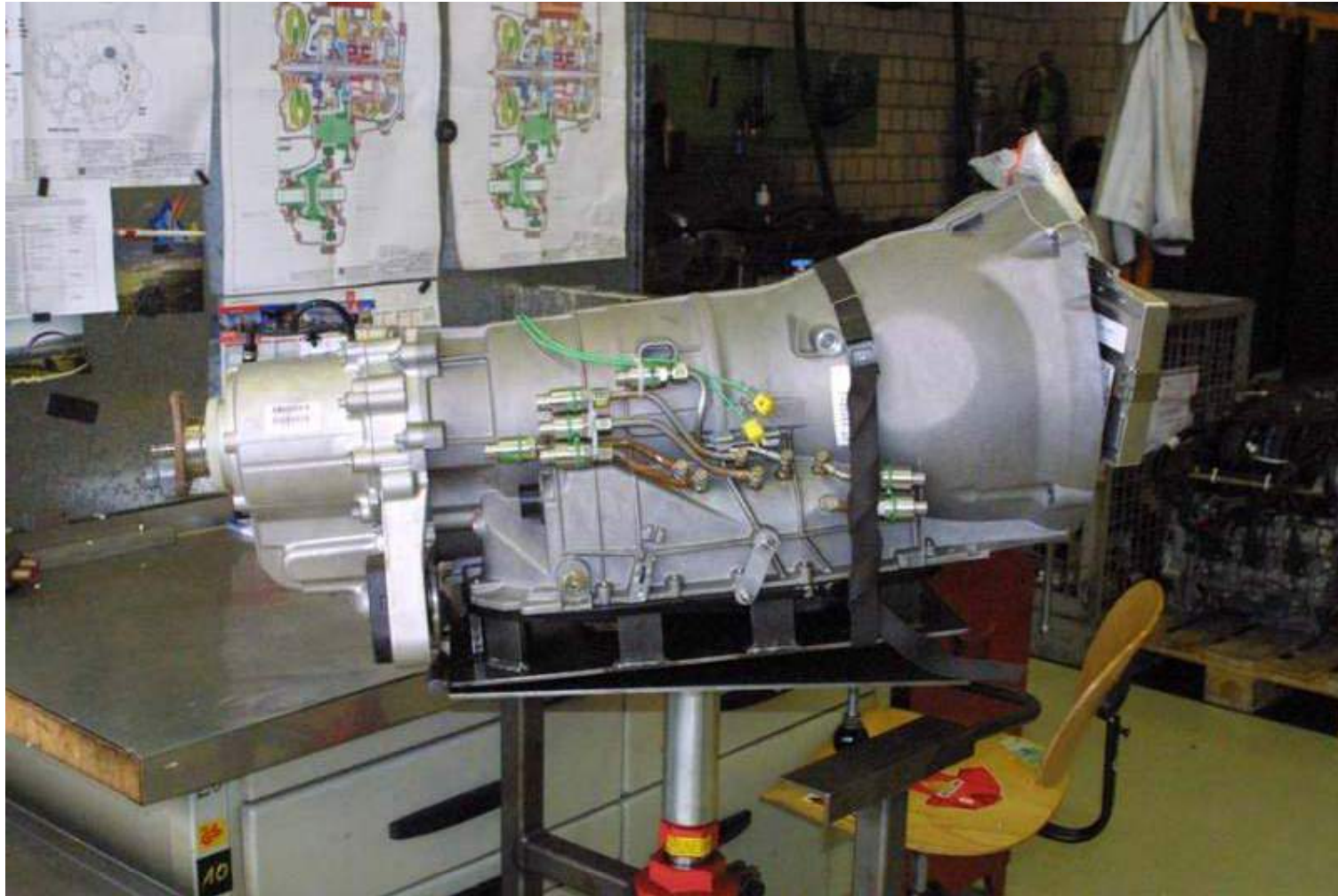



Transmission to be installed into the vehicle

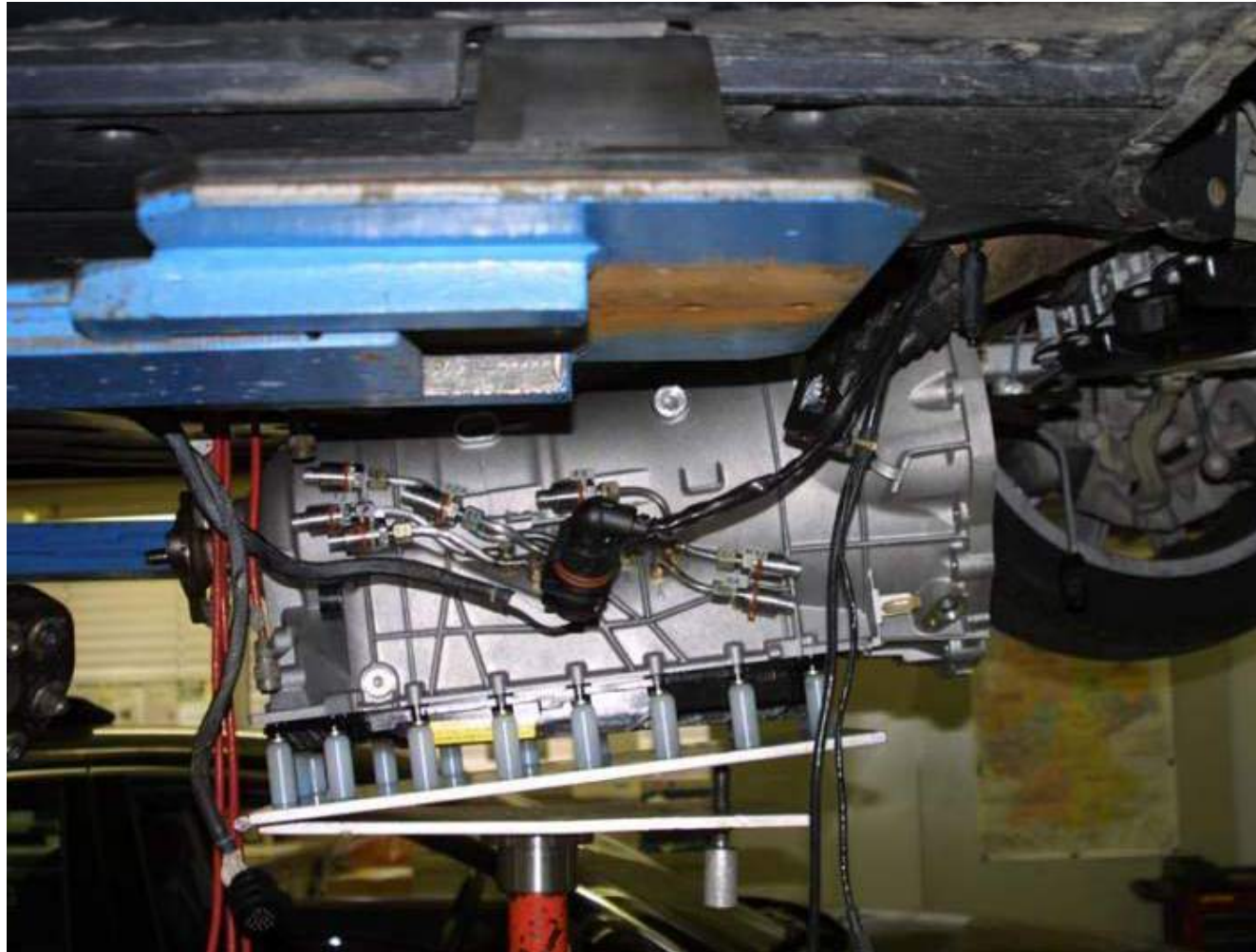



Handling and Storage of an Automatic Transmission

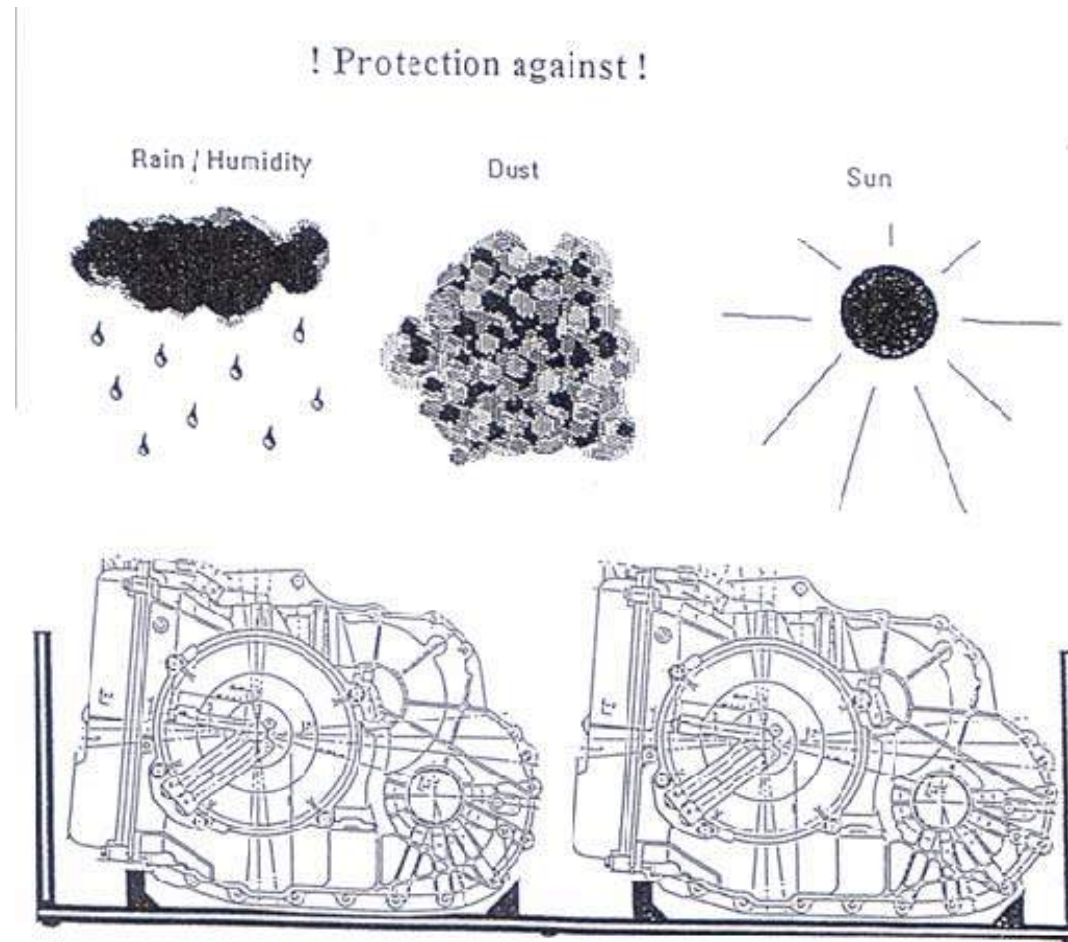



Handling and Assembling of Automatic Transmission and Engine

Remove converter strap right before assembling the gearbox to the engine

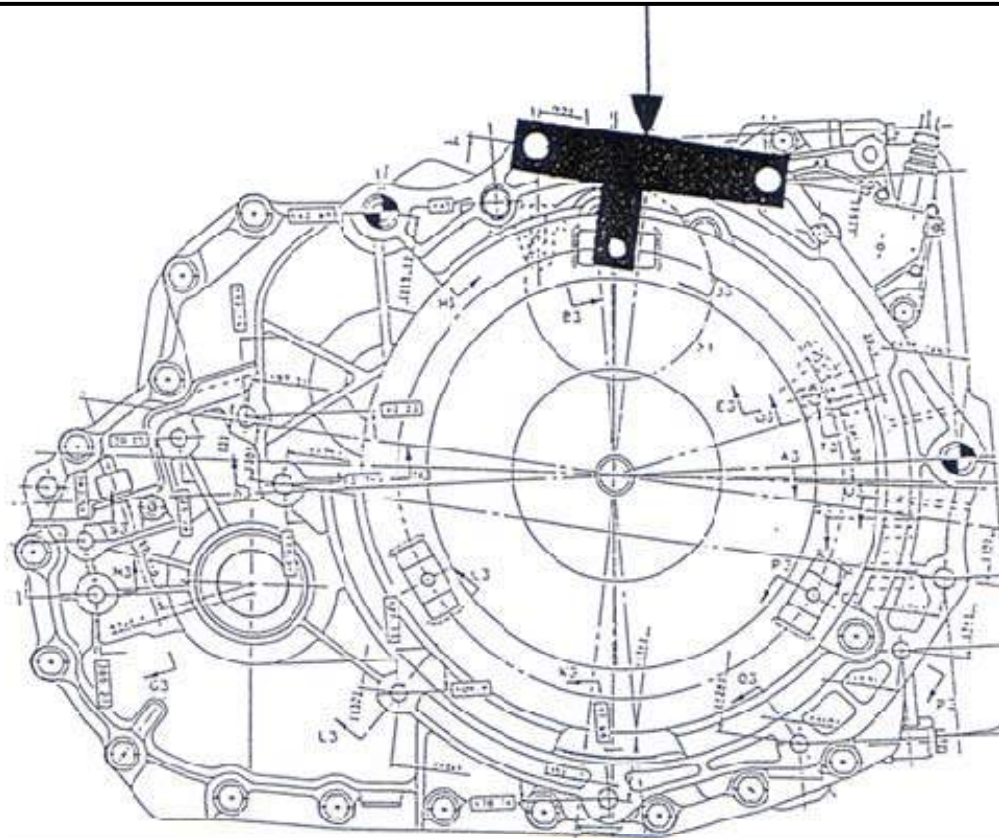



Installation of the Torque Converter

Before assembling the transmission to the engine, it is important that the torque converter is installed correctly (see manual of the special gearbox)



distance from bell housing to
torque converter

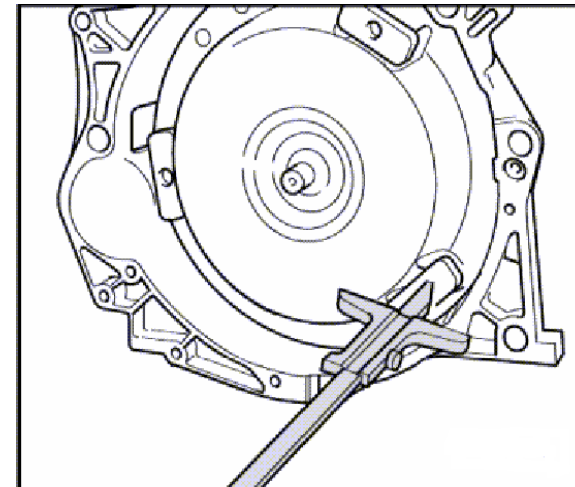

measurement of the
distance with a deep gauge



Pump Gear

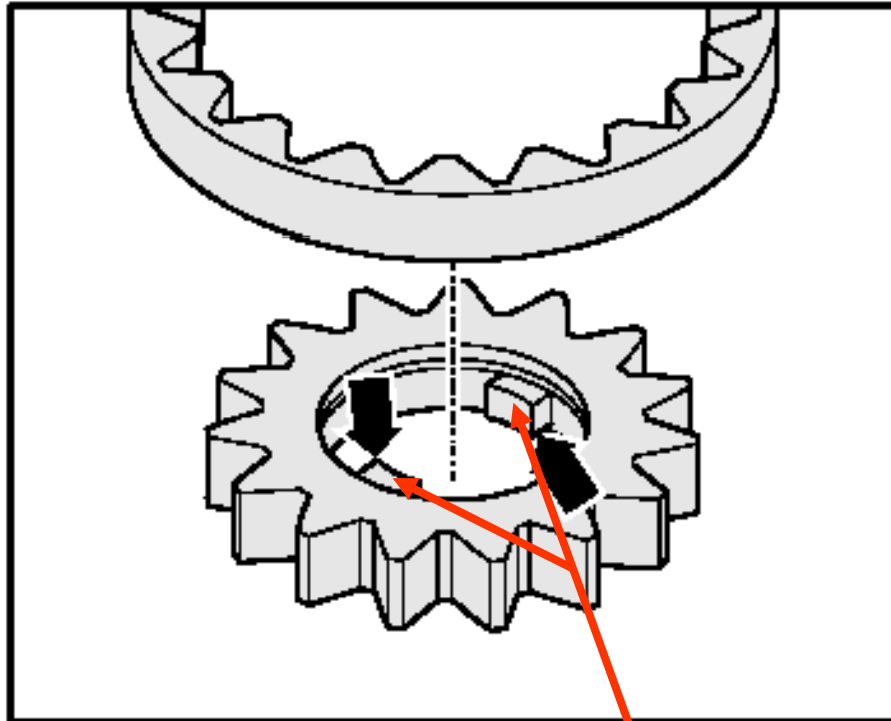

driving pin

Driving pins of the pump can break

Effect:

- no power flow (R,D)



Pump Gear

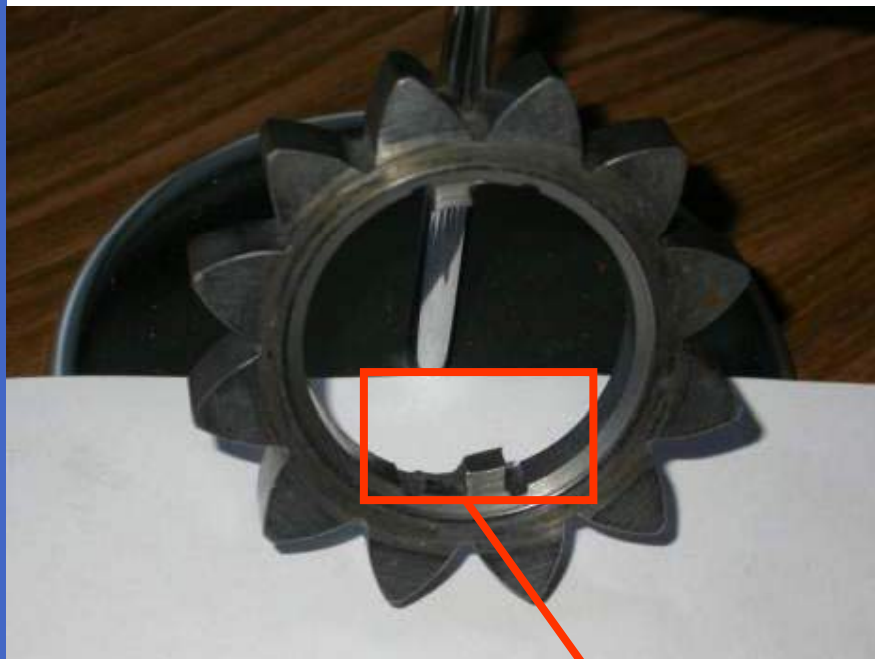

This damage is caused by the wrong installation of the transmission.

Driving pin is broken



Leakage between Engine and Transmission

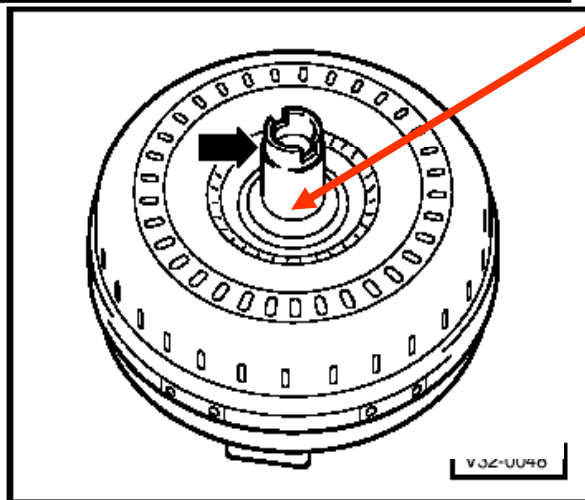
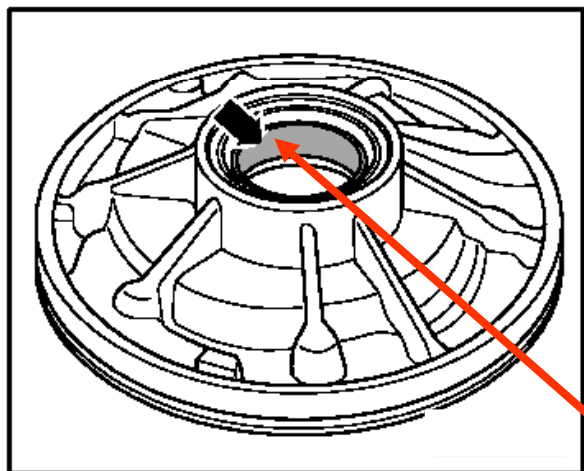

Effect:

- leakage between engine and transmission

Reasons:

- centre bush is missing in crank shaft
- centre pin between engine and transmission is missing



Centre Bush



centre bush

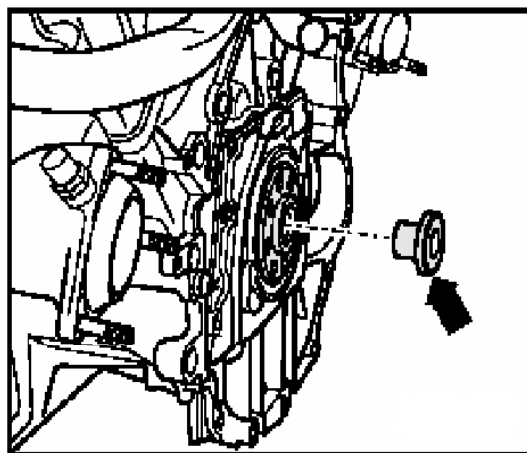

position of the centre bush

After assembling of the transmission to the engine, don't forget to build in the centre bush!

A missing centre bush cause damages of the torque converter and the oil pump!



Centre Pins



center pin

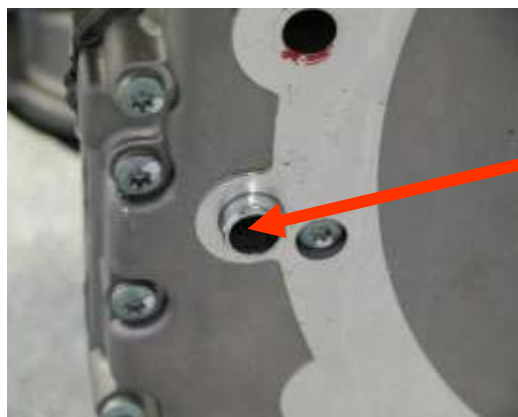

center pin at an engine case

It is very important that the centre pins are assembled to the engine case.
Missing centre pins will cause damages in the transmission.

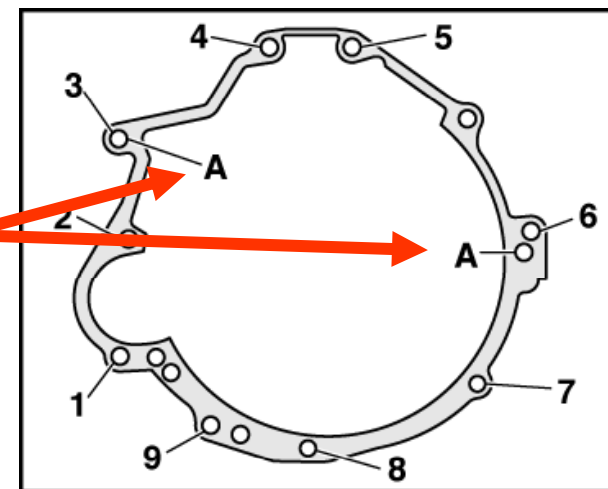

The two A describe the position of the centre pins



Functional test

- After repair you should make a driving test
- Before the driving test you have to delete all adoption values using a tester



The whole product family

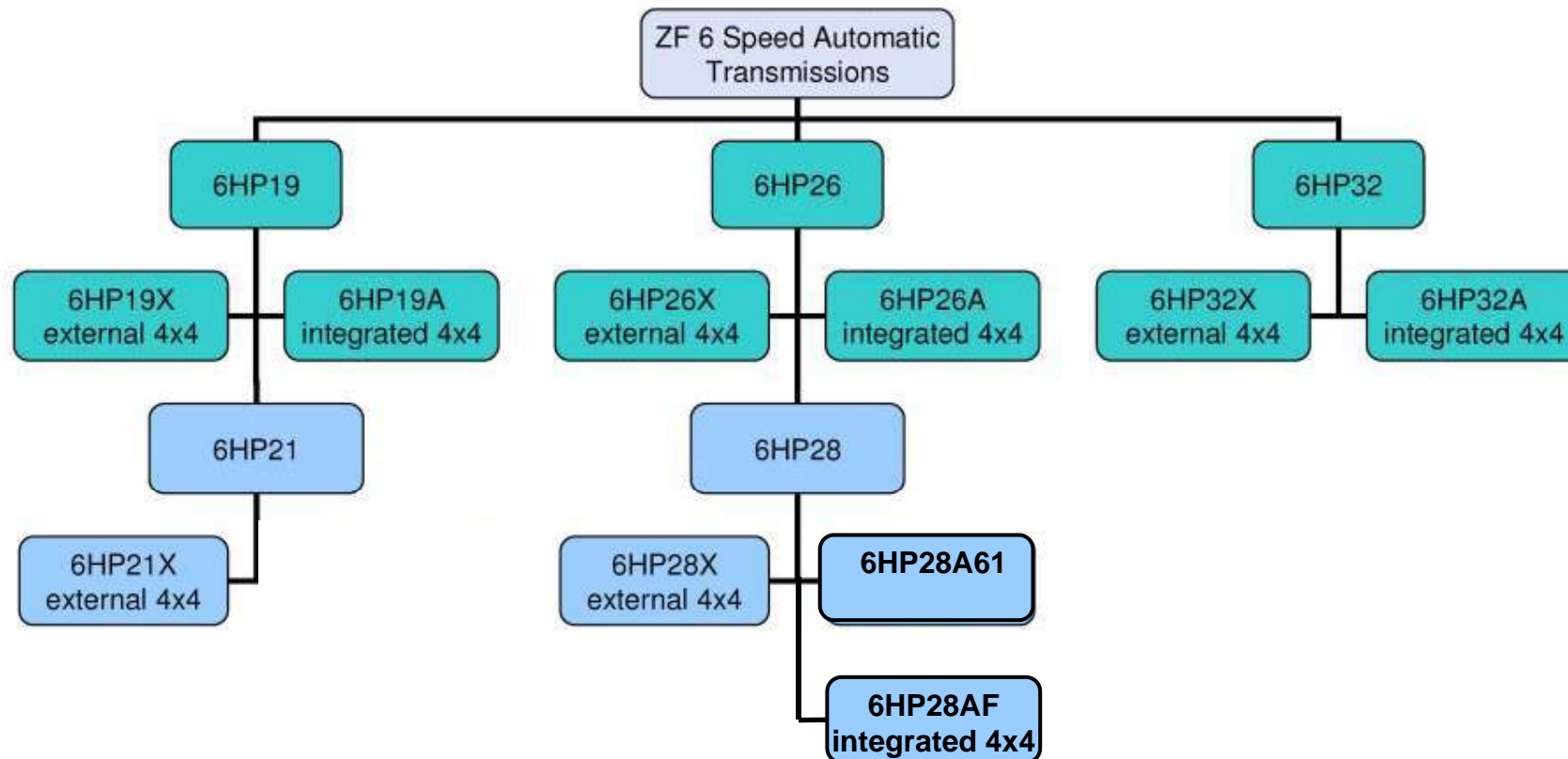



6 speed part numbers

Main Parts List	Trans Type	Part Number Programmed	Description
1071 010 ...	6HP19	1071 012 ...	Rear wheel drive
1071 020 ...	6HP19X	1071 022 ...	External 4x4
1071 040 ...	6HP19A	1071 042 ...	Internal 4x4
4			
1068 010 ...	6HP26	1068 012 ...	Rear wheel drive
1068 020 ...	6HP26X	1068 022 ...	External 4x4
1068 030 ...	6HP26A61	1068 032 ...	Internal 4x4
1070 010 ...	6HP32	1070 012 ...	Rear wheel drive
1070 020 ...	6HP32A	1070 022 ...	Internal 4x4
1070 030 ...	6HP32X	1070 032 ...	External 4x4
1071 030 ...	6HP21	1071 032 ...	Rear wheel drive
1071 050 ...	6HP21X	1071 052 ...	External 4x4
1068 040 ...	6HP28	1068 042 ...	Rear wheel drive
1068 050 ...	6HP28X	1068 052 ...	External 4x4
1068 090 ...	6HP28A61	1068 092 ...	Internal 4x4
1084 030 ...	6HP28AF	1084 032 ...	Internal 4x4

6 speed transmission identification

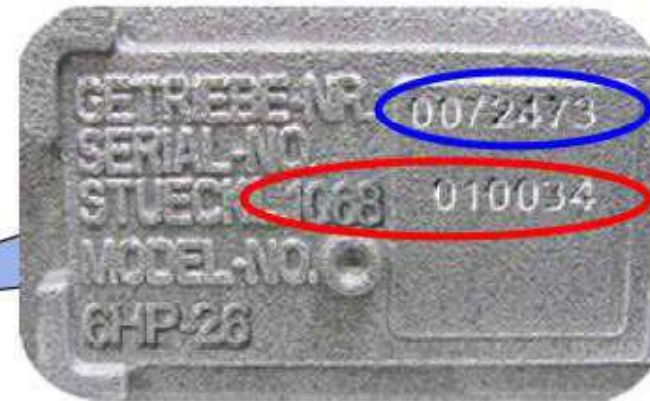

- = Main parts list
- = Serial number
- = Transmission part number



Example transmission application BMW 745



Vehicle production date ranges

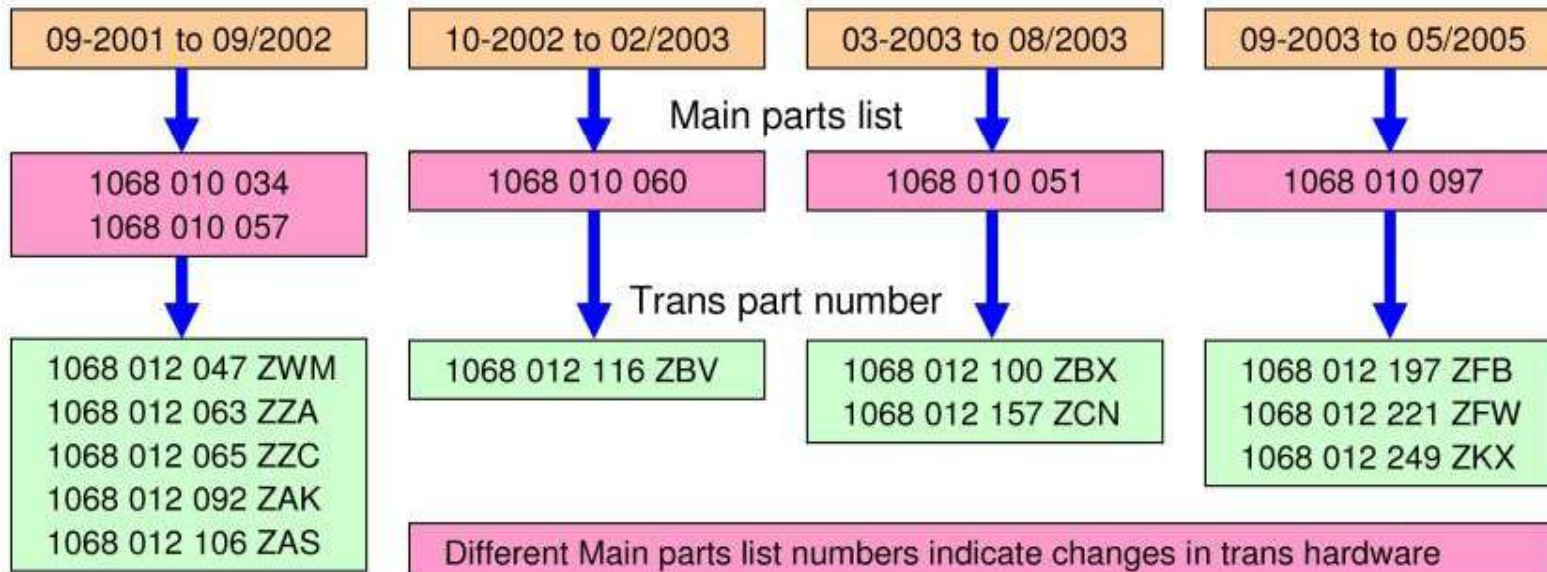

Main parts list

Trans part number

Different Main parts list numbers indicate changes in trans hardware

Different Trans part numbers with the same main parts list number indicate a different software levels



Topics

- Business unit „Automatic transmissions“
- The 6HP gearbox-family
- **Hints for the repairshop**
 - ◆ General hints
 - ◆ gearbox change
 - ◆ **change of a mechatronic**
 - ◆ change of a oilpan and filter
 - ◆ changing or adding oil

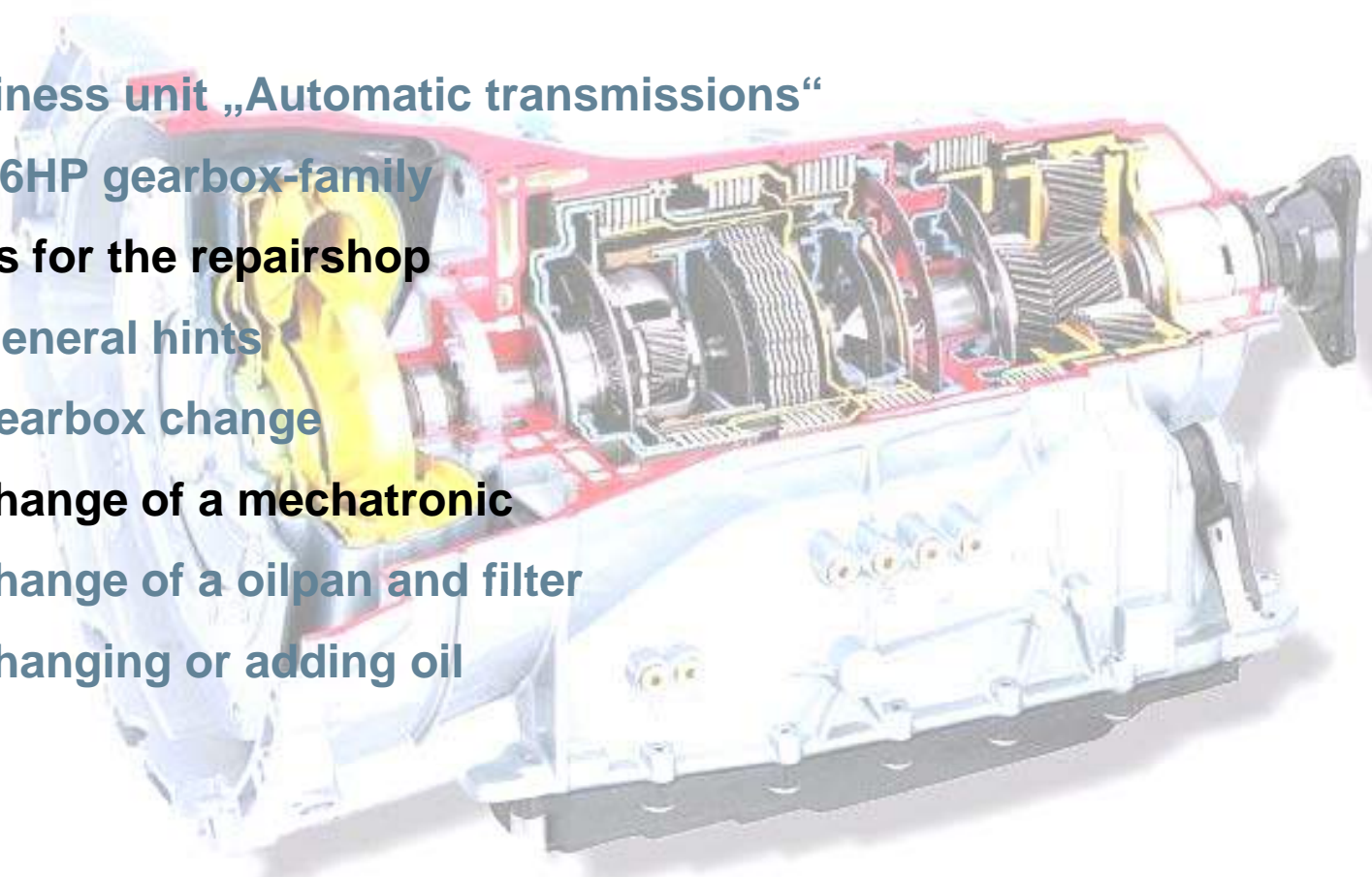



Mechatronics on a special carrier

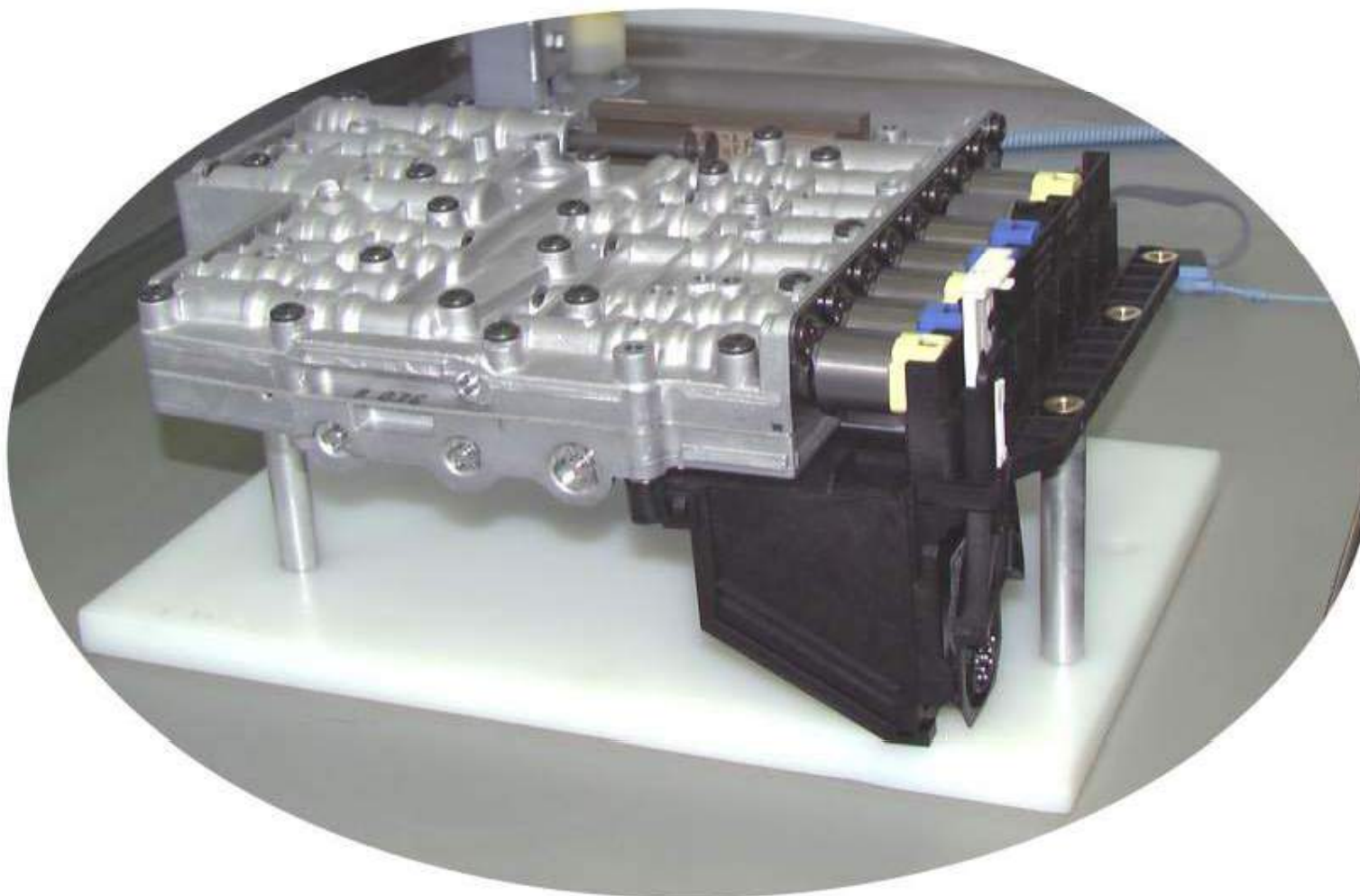



6HP..-Mechatronics

left side: E-version / right side: M-Version

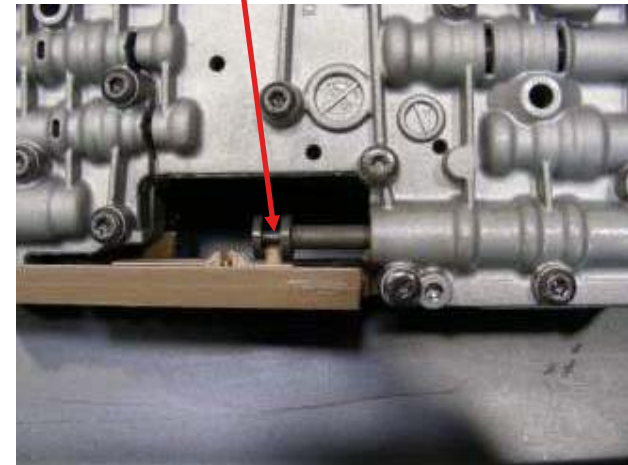
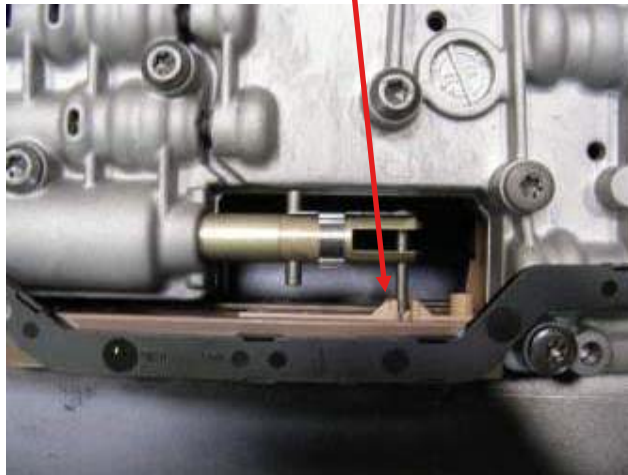
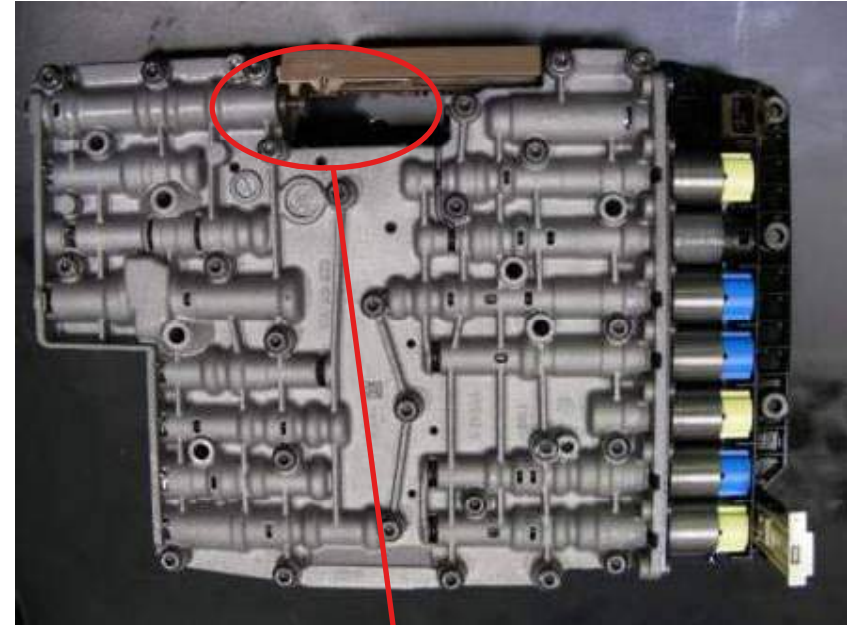
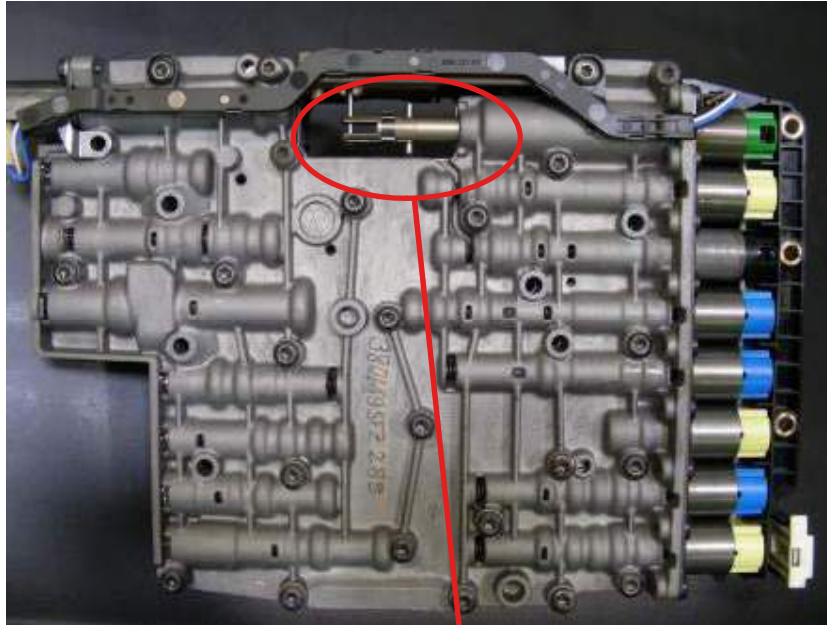



Mechatronik identification

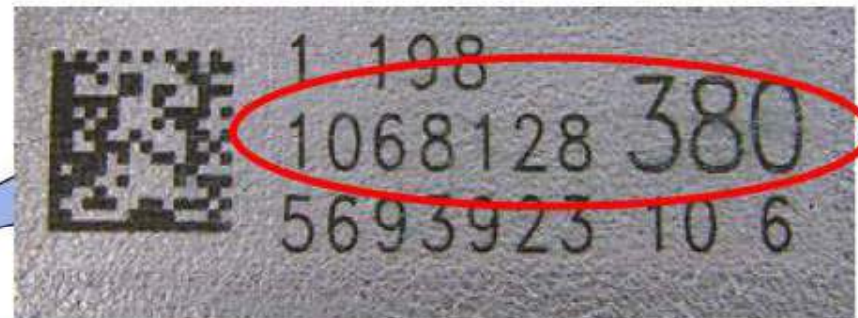

 = Main parts list



Mechatronic replacement



1. Secure vehicle against rolling, secure wheels with wheel chocks.
Important: On some vehicles (E-shift) it is necessary to shift vehicle out of Park to replace the mechatronic.
2. Drain transmission fluid and remove the transmission oil pan.
3. Unlock and disconnect the vehicle connector from the transmission.

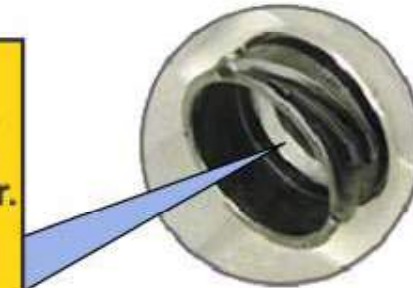

4. Pull the sealing sleeve locking mechanism to the unlocked position. The locking tab is located on the bottom of the mechatronic below the sealing sleeve.
5. Remove the sealing sleeve.



Mechatronic replacement



6. On E-shift applications only (vehicles with emergency release cable)

Important: By moving the emergency release lever backward the transmission is no longer in the park position. Secure against rolling, apply parking brake and secure **wheels with chocks**.

Use a wire tie or mechanics wire and secure the emergency release lever in a slight backwards position as shown.

Important: During the removal and handling of the mechatronic apply special care not to bump, drop or rough handle the unit especially in the area of the MV2 solenoid.

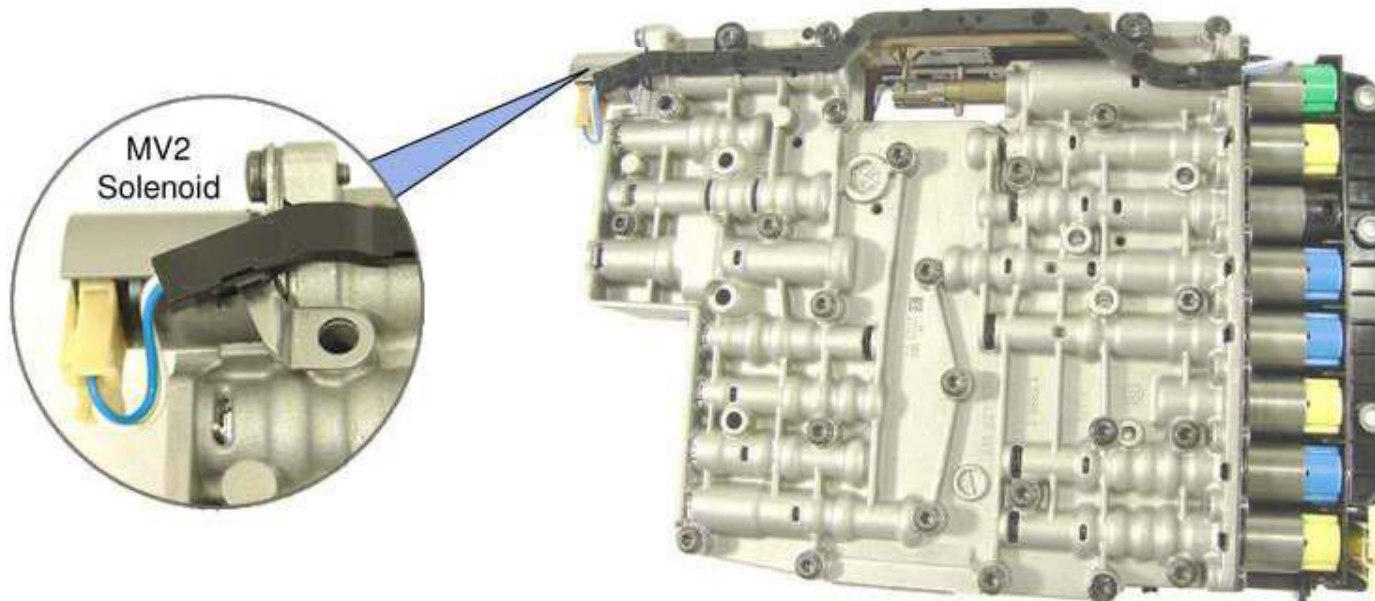



Mechatronic replacement

7. To remove the mechatronic, remove the screws indicated in blue.

Note: There are mechatronic versions with **10** or **13** mounting screws.
Handle mechatronic with care to prevent external damage.

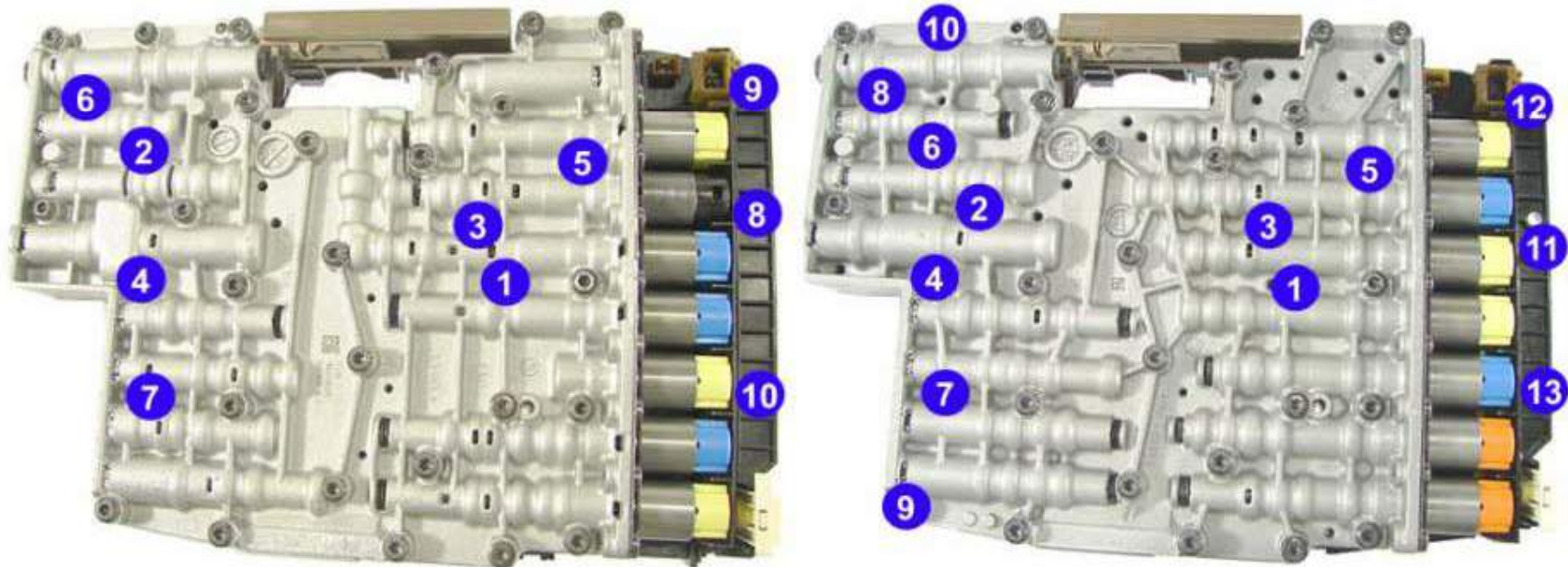



Mechatronic replacement



8. Remove the mechatronic adapter and replace the seals, coat with transmission fluid and reinstall the seal adapter into the transmission case.



E-shift

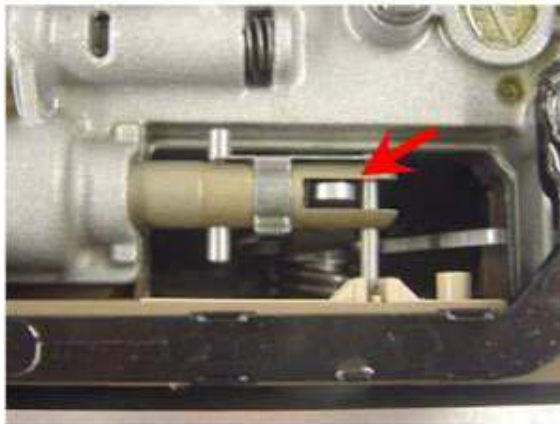

M-shift



9. When installing the replacement mechatronic make sure the park cylinder rod on E-shift or the manual valve on M-shift is properly engaged before installing any of the mechatronic mounting bolts.



Mechatronic replacement

10. Use hand tools – Do not use power tools for screw installation.

First install and turn screw **1** and **4** alternately until seated then install all other screws until they make contact with the mechatronic. After all screws are installed, tighten screws in order **1** to **10** or **13** as shown in the schematic below.

Torque for screws is **8 Nm ± 0.8 Nm**.

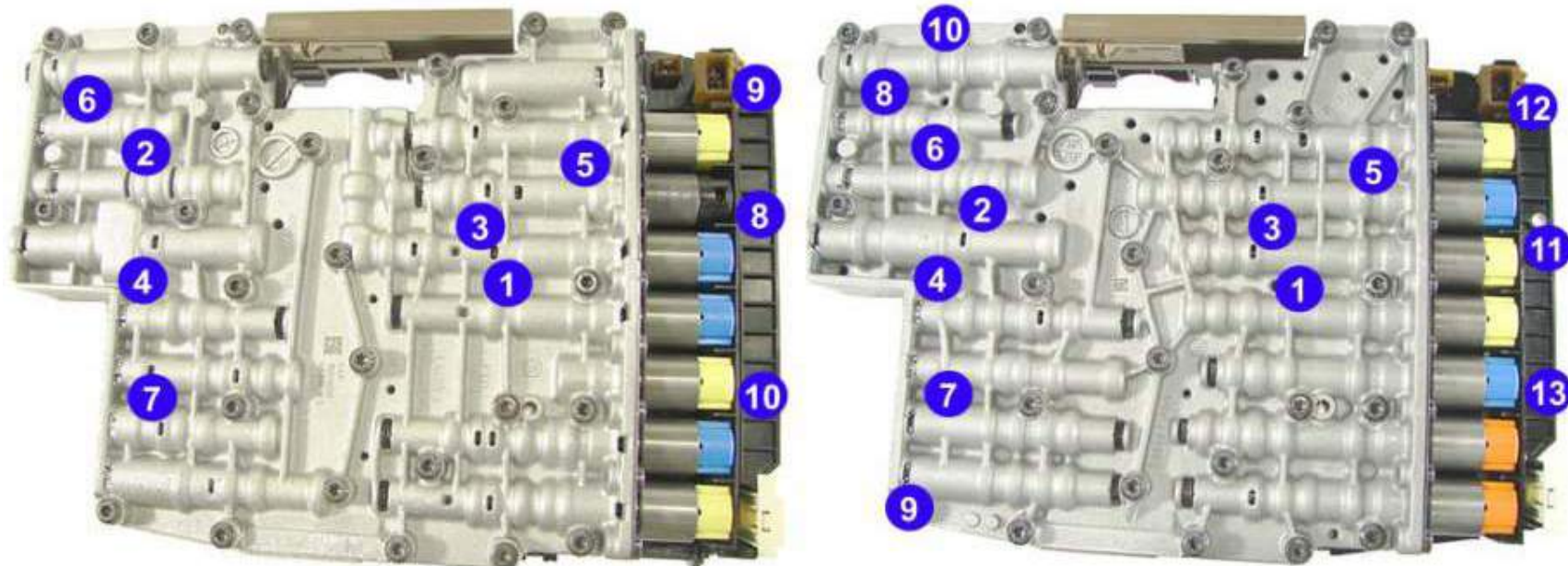



Mechatronic replacement

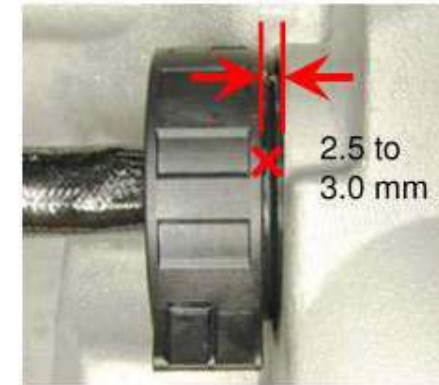
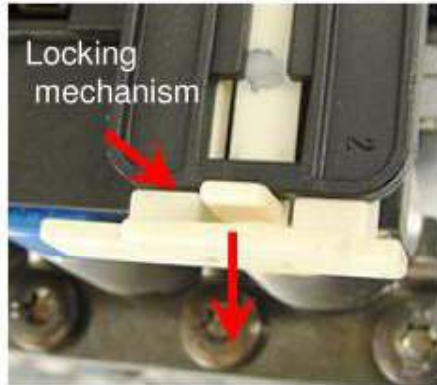

- Unlock the sealing sleeve locking mechanism and install the sealing sleeve with the locating tab properly aligned with the mechatronic. Use transmission fluid to lubricate the seals for installation. After the sleeve is properly seated, push the locking mechanism to the locked position. Install the vehicle connector plug and check that the sleeve is properly seated. The gap x should be between **2.5 to 3.0 mm**.





Mechatronic replacement

12. Install the oil pan and attach all screws until they just make contact with the oil pan. After all screws are installed, tighten screws in order **1** through **21** or **24** as shown in the schematic below.

The tightening torque for screws on a plastic oil pan is **10 Nm ± 1.0 Nm**.

The tightening torque for screws on a steel oil pan is **12 Nm ± 1.0 Nm**.

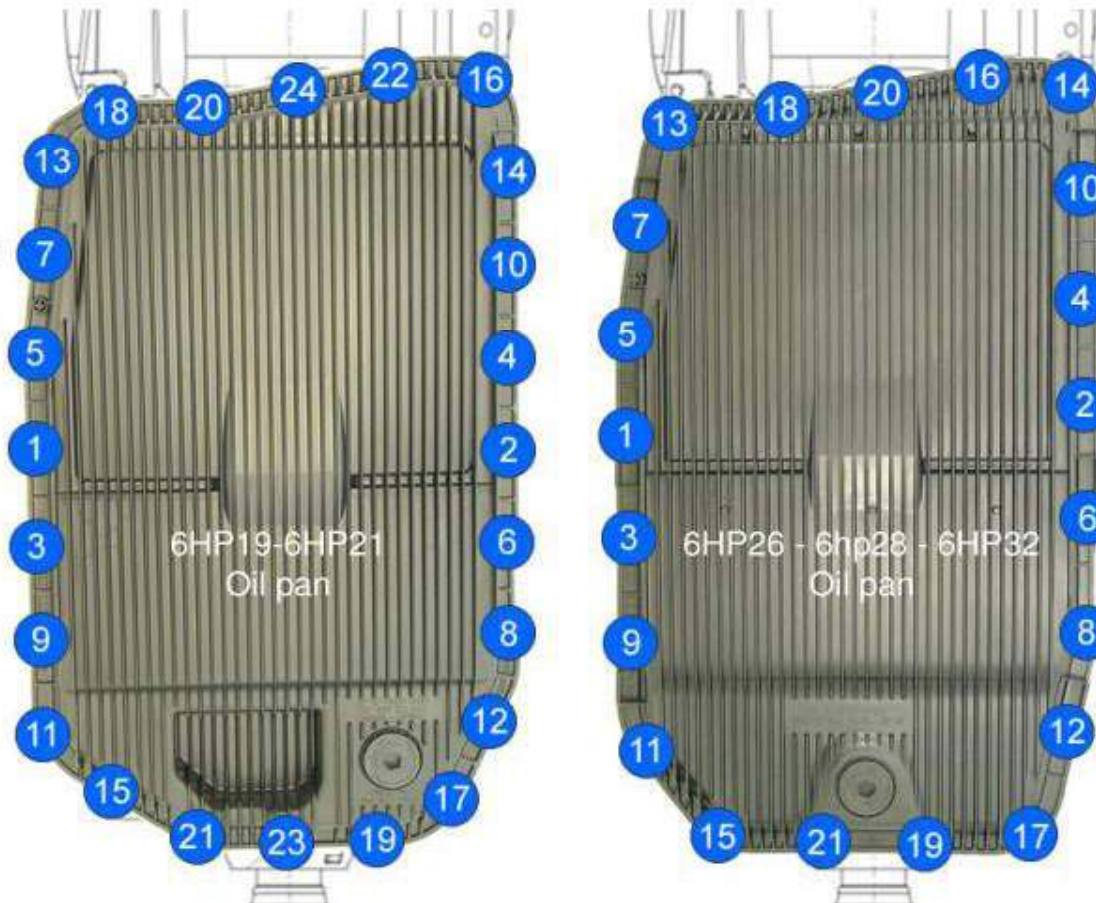



Mechatronic replacement

13. E-shift vehicles, remove the tie strap or wire that held the emergency park release lever in the backwards position and adjust cable as follows.



With the emergency cable released the clearance X indicated above must be adjusted to **1.0 to 2.0 mm**.

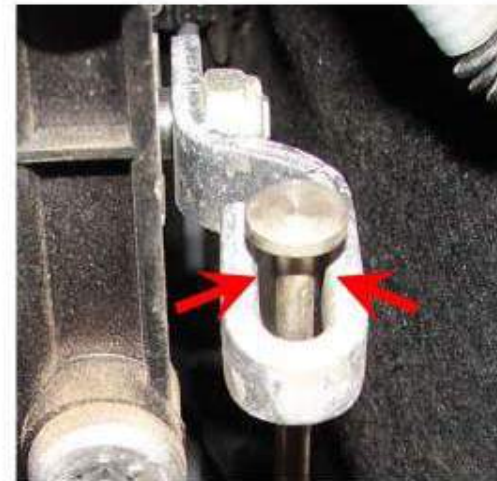

The cable should not touch the lever at any time, even if the lever is moved back and forth. If the cable does come in contact then check for a bent lever or a bent cable bracket.

14. Add and adjust transmission fluid level following the appropriate filling procedure.



Topics

- Business unit „Automatic transmissions“
- The 6HP gearbox-family
- Hints for the repairshop
 - ◆ General hints
 - ◆ gearbox change
 - ◆ change of a mechatronic
 - ◆ change of a oilpan and filter
 - ◆ changing or adding oil

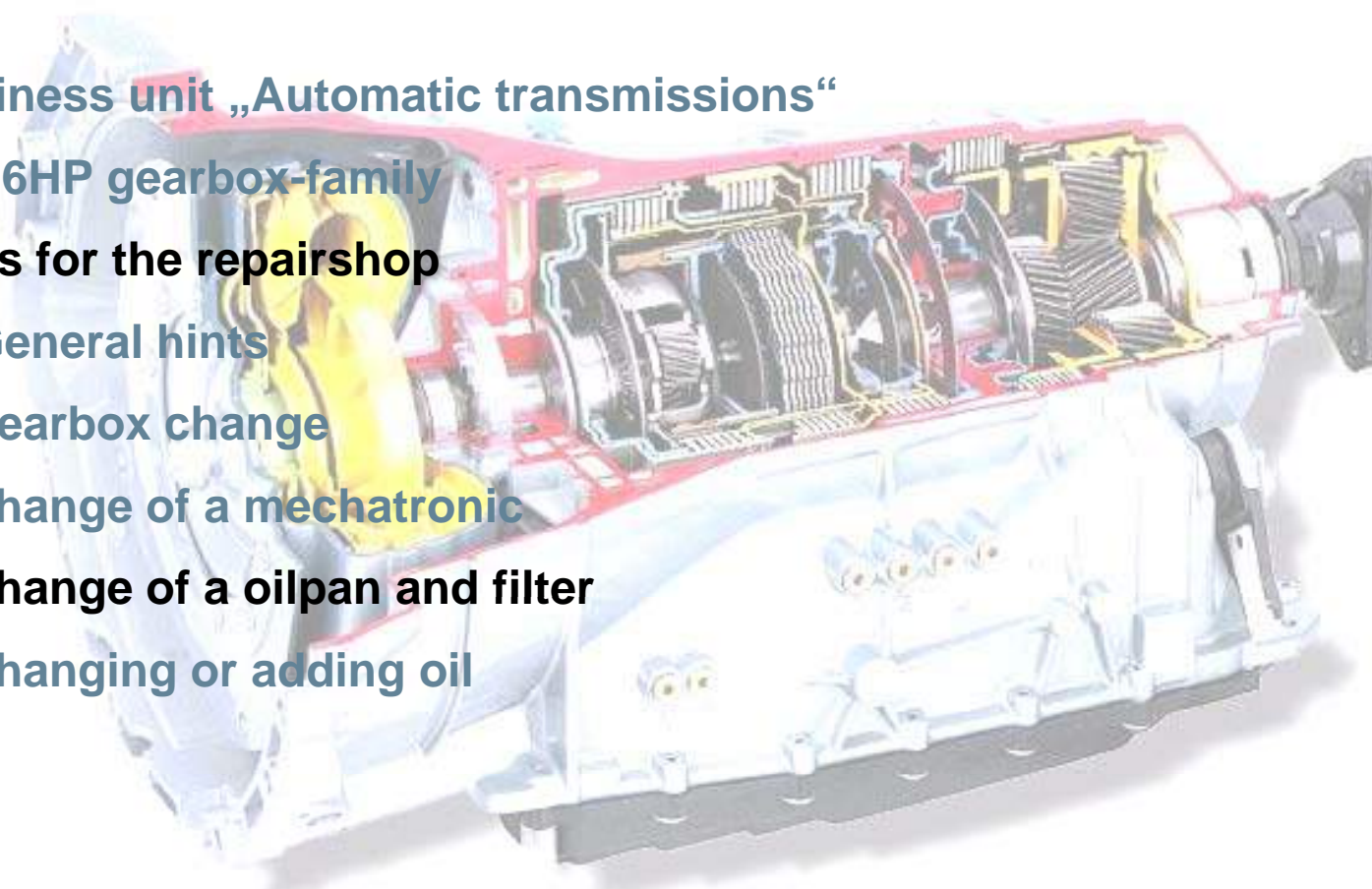



Polyamide oilpan with integrated filter

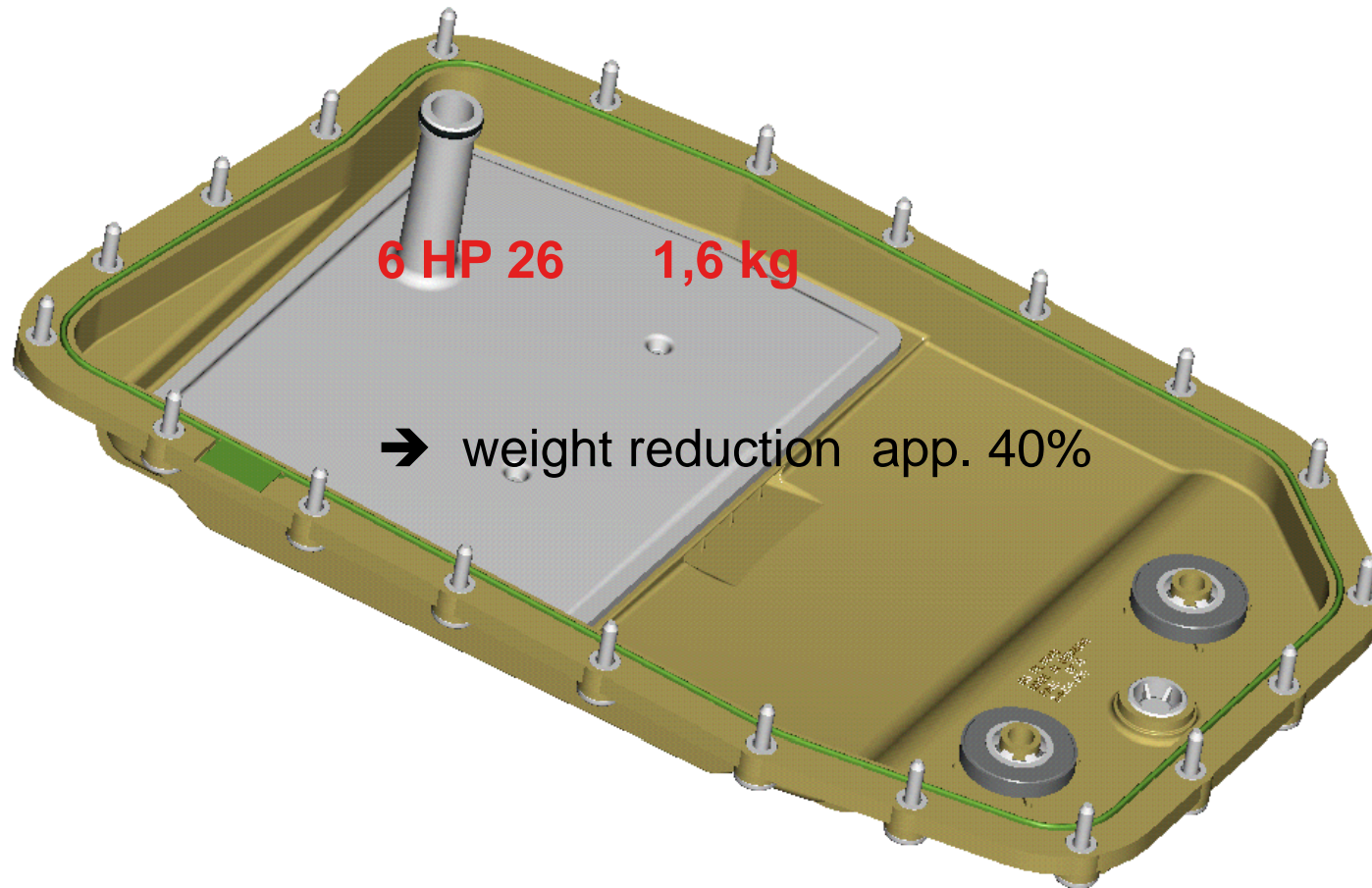



ZF-part number (Polyamide oilpan)

<i>ZF part number</i>	<i>name</i>	<i>gearbox</i>	<i>Customer</i>
1068 298 033	Oilpan	6HP26 / 28 / 28X / 32	BMW
0501 215 789	Oilpan	6HP26 / 26X	Aston Martin, Ford USA, Ford Australia Jaguar, Range Rover
1071 298 009	Oilpan	6HP19 / 19X / 21 / 21X	BMW



Plate Oilpan and Oilfilter





ZF Part Number: Plate oilpan and Oilfilter 1

ZF-part number	Name	Gearbox	Customer
1068 203 042	Oilpan	6 HP 26 X	Ford USA
1068 203 044	Oilpan	6 HP 26 X	BMW
1068 203 046	Oilpan	6 HP 26	Maserati
1068 203 048	Oilpan	6 HP 26	Ford Australia
0501 213 359	Filter		
1068 303 017	Sealing		
1068 203 043	Oilpan	6 HP 26 A	Audi, Bentley
0501 212 974	Filter		
1068 303 012	Sealing		
1068 203 047	Oilpan	6 HP 26 A	Audi, Bentley
0501 212 974	Filter		
0501 322 155	Sealing		



ZF Part Number: Plate oilpan and Oilfilter 2

ZF-part number	Name	Gearbox	Customer
1070 203 010	Oilpan	6 HP 32	BMW
0501 213 359	Filter		
1068 301 017	Sealing		
1070 203 008	Oilpan	6 HP 32 A	VW
0501 212 974	Filter		
1070 303 009	Sealing		
1071 203 038	Oilpan	6 HP 19 A	Audi, VW
0501 212 401	Filter		
1071 303 006	Sealing		
1071 203 039	Oilpan	6 HP 19 A	Audi, VW
0501 212 401	Filter		
0501 322 078	Sealing		
1071 203 040	Oilpan	6 HP 19 X	Audi
0501 214 315	Filter		
0501 322 077	Sealing		



Topics

- Business unit „Automatic transmissions“
- The 6HP gearbox-family
- Hints for the repairshop
 - ◆ General hints
 - ◆ gearbox change
 - ◆ change of a mechatronic
 - ◆ change of a oilpan and filter
 - ◆ changing or adding oil

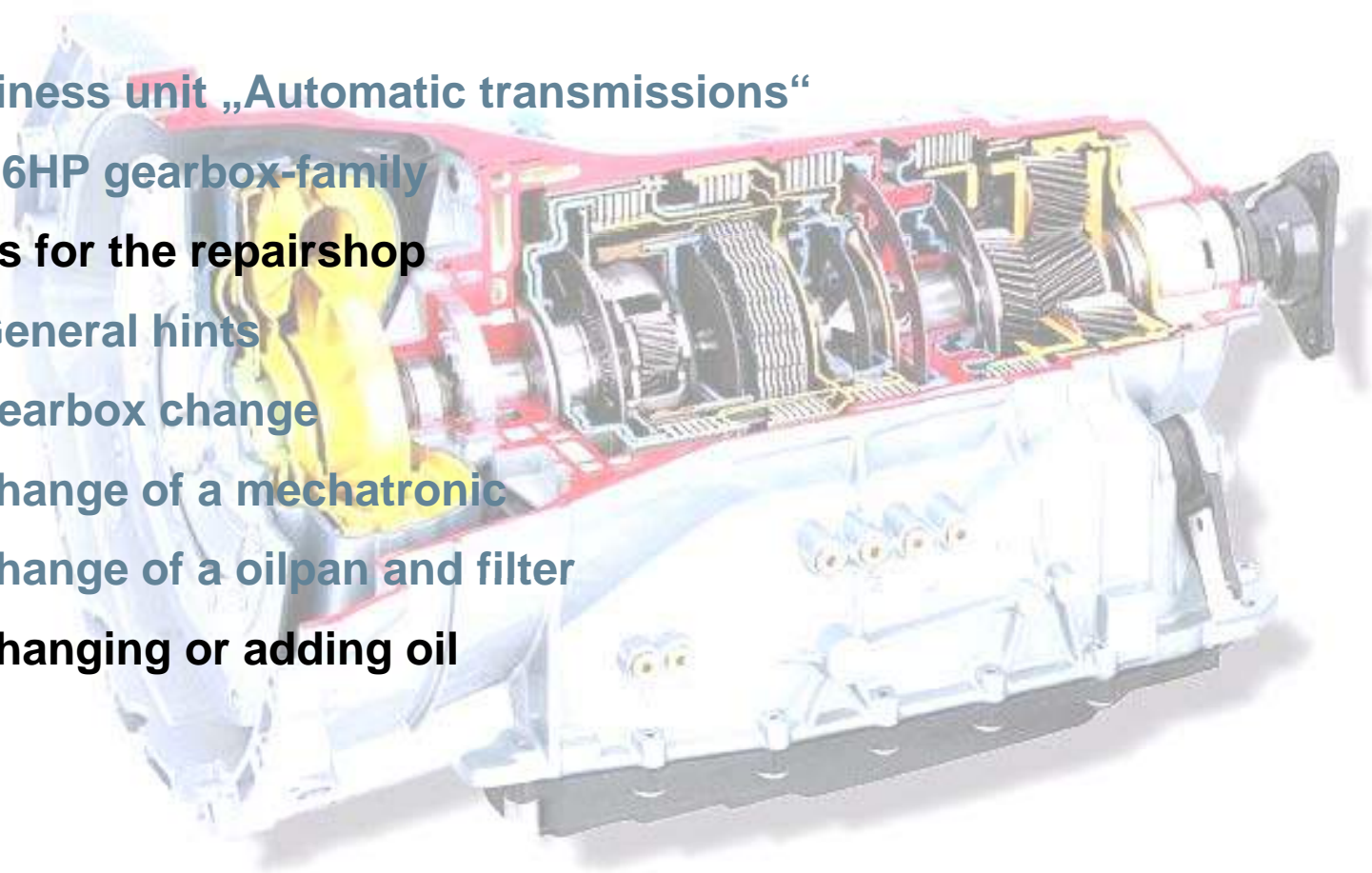



General Hints on Transmission Oil

- Do not mix different oils unless this is expressly prescribed.
- Clean the oil cooler in the opposite direction from normal flow before fitting the transmission unit, i.e. starting from the transmission feed (VK) and not from the return (ZK). Cleaning unit is commercially available.



6HPxx transmission fluid level procedures

Note: This is a generic 6 speed transmission fluid level procedure.

Depending on the transmission, the oil pan and vehicle application there might be different parameters and procedures might apply.

A) Transmissions fluid level checking.

The transmission fluid temperature must be between 30 °C and 35 °C before checking can begin. Use test equipment to determine the trans temperature.

The vehicle must be level with engine running at idle speed and air conditioning turned on.

Step on the brakes firmly, apply parking brake fully and shift to D and R, briefly pausing in each position before shifting back to the Park position.

With the engine running at idle speed and the selector in Park position, remove the filler plug. Monitor the transmission temperature, if a small stream of oil runs out at 40 °C, the fluid level is correct.

If no oil runs out when the filler plug is removed, the fluid level is too low and oil needs to be added until it overflows.

With engine running, install the oil filler plug and tighten to proper torque.

B) Adding fluid after repairs.

With the engine stopped and the transmission in Park position, remove the oil filler plug. Add transmission fluid until a small stream of oil runs out.

Insert the filler plug and tighten by hand. Start the engine.

With the engine running, remove the oil filler plug and add transmission fluid until a small stream of oil runs out. Insert the filler plug and tighten by hand.

Follow the "Transmission fluid level checking" procedure described in section **A)** above.



6HPxx transmission fluid level procedures

C) Notes on fluid level and adding procedure.

Use only ZF-LifeguardFluid6 or OE approved transmission fluid.

If the transmission temperature rises above 50 °C during the fluid level checking procedure the resulting oil level will be too low. Let the transmission cool down and repeat the fluid level procedure.

Have transmission fluid and a suitable oil pump available before starting the fluid level procedure. The transmission fluid temperature will rise quickly during the checking procedure.

D) Drain and filler plug location.

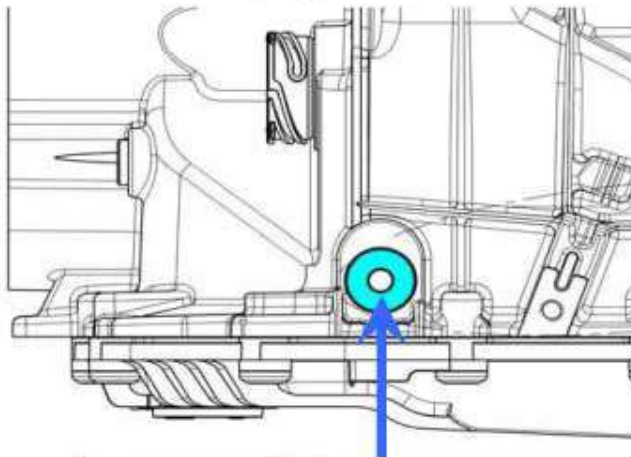

Filler plug **M18x1.5**
Inner hexagon **8mm**
Tightening torque **35 Nm ± 3.5 Nm**

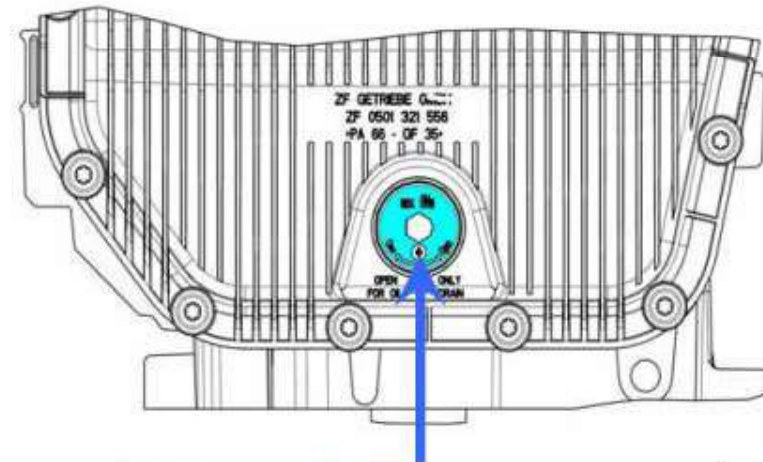

Drain plug **M24x1**
Inner hexagon **10mm**
Tightening torque **8 Nm - 0.5 Nm**



ATF Oil-Check 6HP19 A

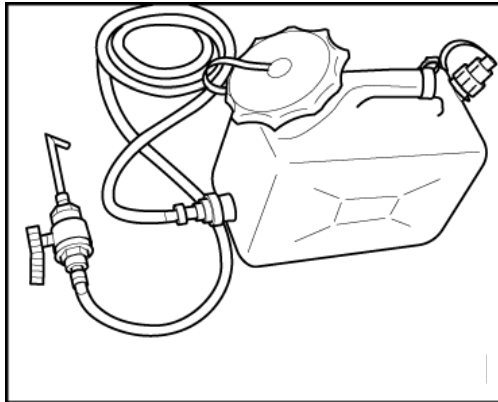

Before drive test the ATF have to be filled up with the **ZF Lifeguardfluid 6**

Fill up instruction: The idle speed should be $n_{eng} = 750$ rpm and the transmission oil pan temperature (CGT) 30 ... 50 °C

Oil volume: 9 l transmission oil No. S671.090.255 (yellow)
 1,05 l differential oil No. S671.090.163
 and 0,528 l Torsen differential oil No. S671.090.163
 and 0,022 l Sturaco oil No. S671.090.167

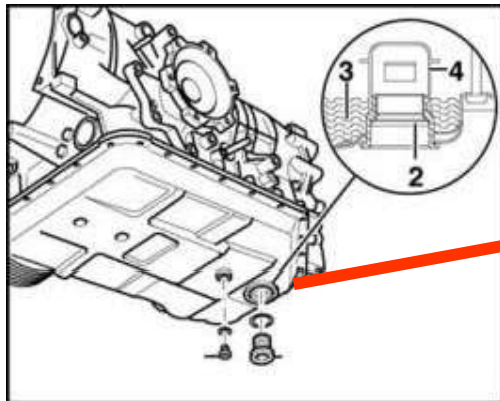

only these 4 MPL!!

VW

1071 040 010

1071 040 022

Audi

1071 040 014

1071 040 044

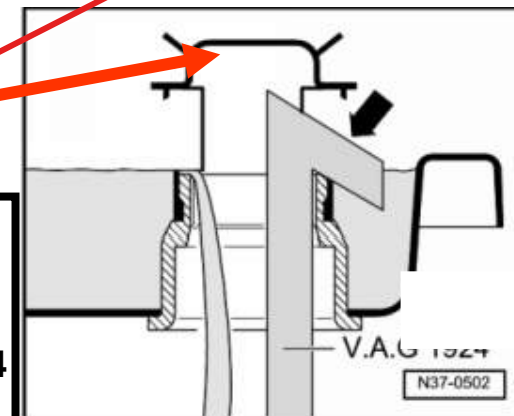



ATF Oil-Check 6HP26A61 Audi

Before drive test the ATF have to be filled up with the **ZF Lifeguardfluid 6**

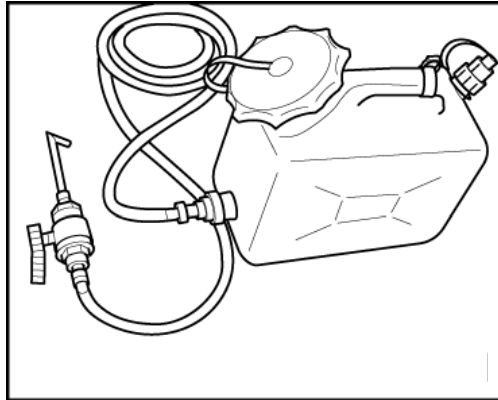

Fill up instruction: The idle speed should be $n_{eng} = 750$ rpm and the transmission oil pan temperature (CGT) 30 ... 50 °C

Oil volume: 10 l transmission oil No. S671.090.255 (yellow) and 1,2 l differential oil No. S671.090.163

Version 1: 0,96 l Torsen differential oil No. S671.090.163 and 0,04 l Sturaco oil No. S671.090.167

Version 2: 1,152 l Torsen differential oil No. S671.090.163 and 0,048 l Sturaco oil No. S671.090.167

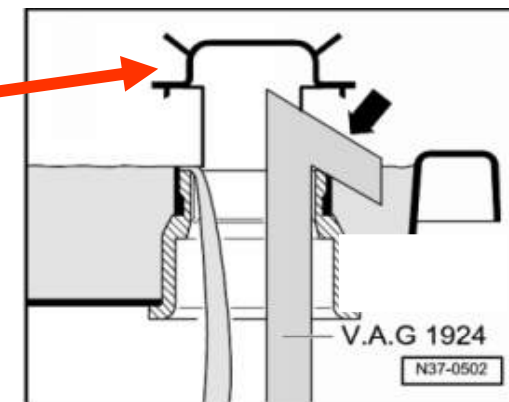
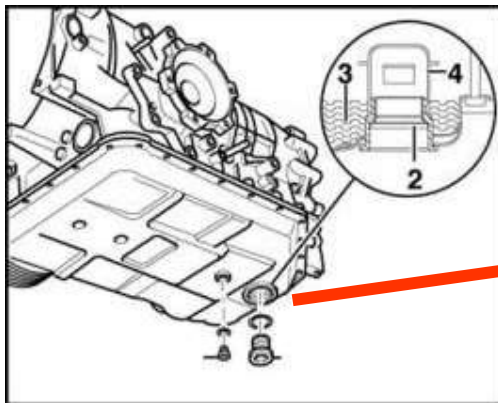



ATF Oil-Check 6HP26A61 Bentley

Before drive test the ATF have to be filled up with the
ZF Lifeguardfluid 6

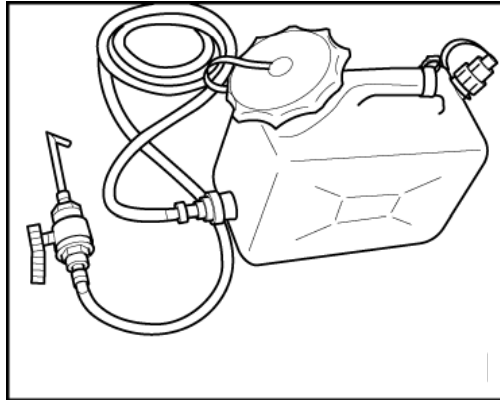

Fill up instruction: The idle speed should be $n_{eng} = 750$ rpm
and the transmission oil pan temperature (CGT)
30 ... 50 °C

Oil volume: 11,2 l transmission oil No. S671.090.255 (yellow)
1,20 l differential oil No. S671.090.163

Version 1: 1,20 l Torsen differential oil No. S671.0920.163
and 0,1 l Sturaco oil No. S671.090.167

Version 2: 1,680 l Torsen differential oil No. S671.090.163
and 0,12 l Sturaco oil No. S671.090.163
(only 1 MPL)

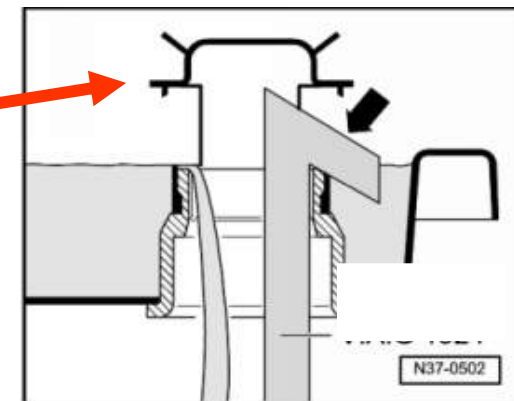
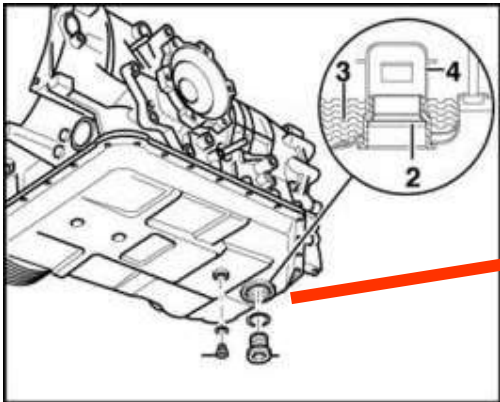



ATF Oil-Check 6HP32A VW

Before drive test the ATF have to be filled up with the **ZF Lifeguardfluid 6**

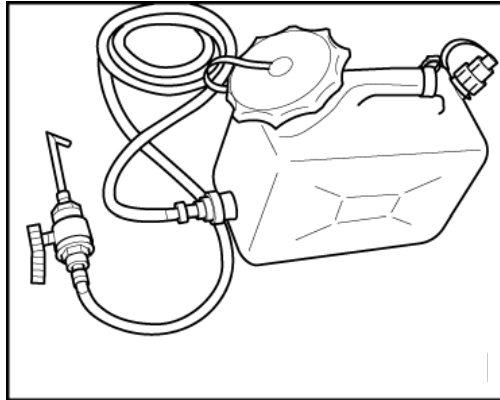

Fill up instruction: The idle speed should be $n_{eng} = 750$ rpm and the transmission oil pan temperature (CGT) 30 ... 50 °C

Oil volume: 10 l transmission oil No.S671.090.255 (yellow)
0,816 l differential oil No. S671.090.163
and 1,104 l Torsen differential oil No. S671.090.163
and 0,046 l Sturaco oil No. S671.090.167

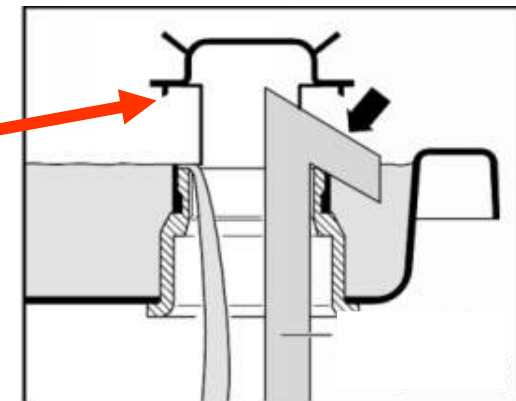
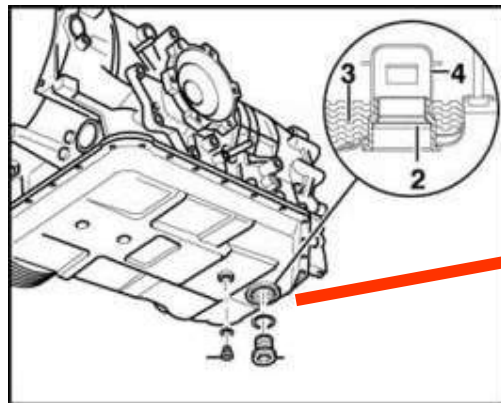



Colour of Lifeguardfluid 6 (yellow)





ATF Oil-Check 6HP26A61 (W12)

Before drive test the ATF have to be filled up with the **ZF Lifeguardfluid 6 Plus**

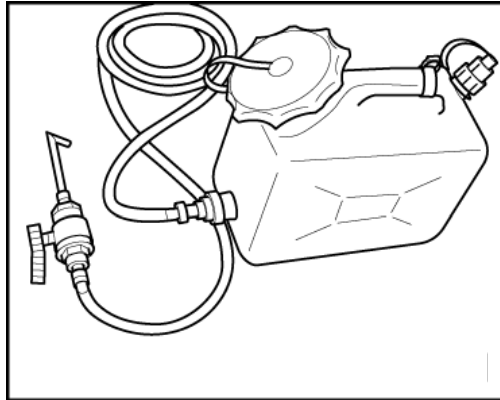

Fill up instruction: The idle speed should be $n_{eng} = 750$ rpm and the transmission oil pan temperature (CGT) 30 ... 50 °C

Oil volume: 10 l transmission oil No. S671.090.281 (blue) and 1,2 l differential oil No. S671.090.163

Version 1: 1,104 l Torsen differential oil No. S671.090.163 and 0,096 l Sturaco oil No. S671.090.167

Version 2: 1,008 l Torsen differential oil No. S671.090.163 and 0,092 l Sturaco oil No. S671.090.167

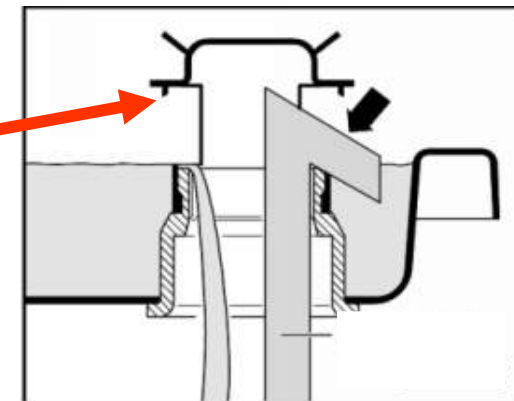
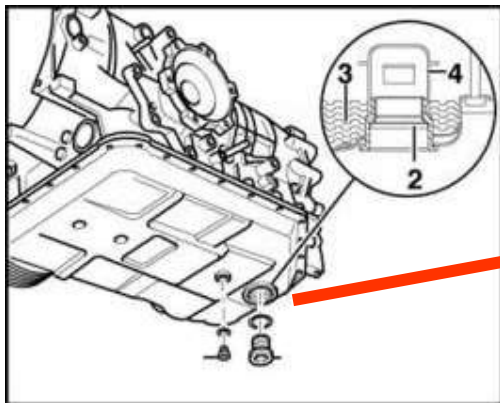

Colour of Lifeguardfluid 6 Plus (blue)





ATF Oil-Check 6HP19A / X VW, Audi

Before drive test the ATF have to be filled up with the **ZF Lifeguardfluid 8**

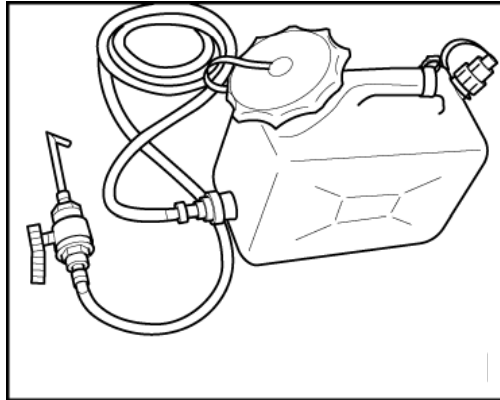

Fill up instruction: The idle speed should be $n_{eng} = 750$ rpm and the transmission oil pan temperature (CGT) 30 ... 50 °C

Oil volume: 9 l transmission oil No. S671.090.311 (green) and 1,05 l differential oil No. S671.090.163 and 0,528 l Torsen differential oil No. S671.090.163 and 0,022 l Sturaco oil No. S671.090.167

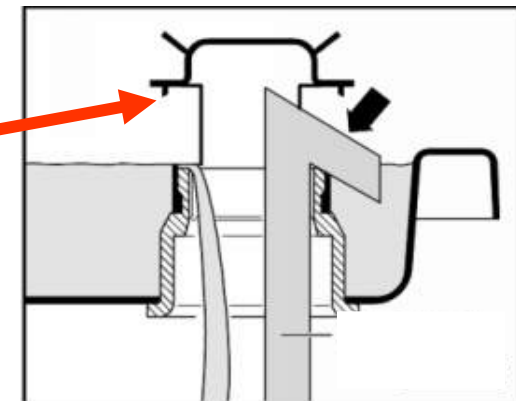
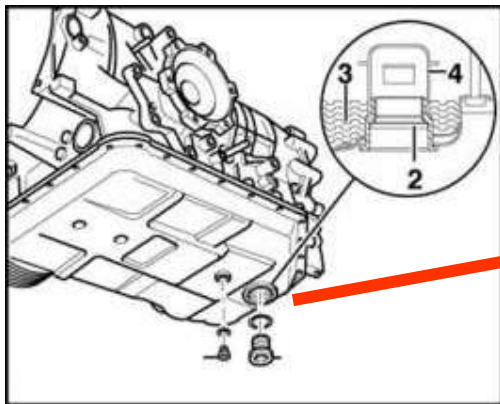



ATF Oil-Check 6HP28AF Audi

Before drive test the ATF have to be filled up with the **ZF Lifeguardfluid 8**

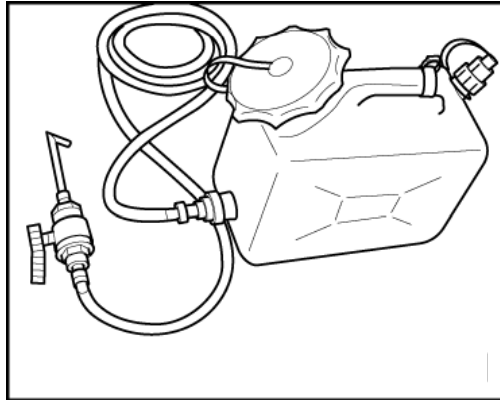

Fill up instruction: The idle speed should be $n_{eng} = 750$ rpm and the transmission oil pan temperature (CGT) 30 ... 50 °C

Oil volume: 10l transmission oil No. S671.090.311 (green) and 1,0 l differential oil No. S671.090.163 and 0,96 l Torsen differential oil No. S671.090.163 and 0,04 l Sturaco oil No. S671.090.167

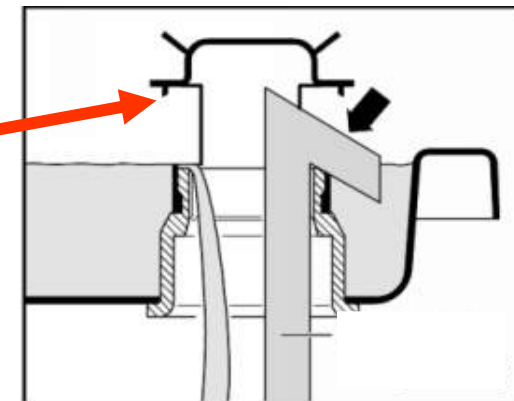
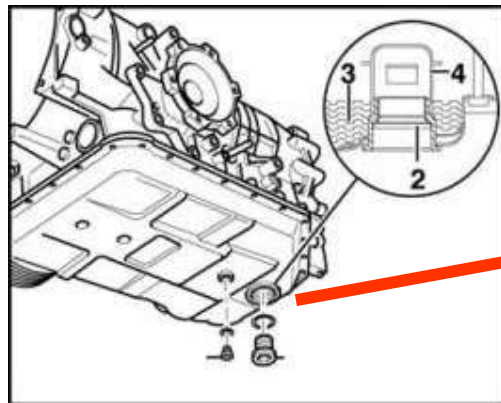



Colour of Lifeguardfluid 8 (green)





Checking and top up the Oil

Lifeguardfluid 6 (yellow)

BMW, Jaguar, Ford,
Maserati, Hyundai, L.Rover,
Aston Martin, RR,
BMW, Bentley

for the gearbox types

6HP19/26/32/21/28/19X/26X/28X

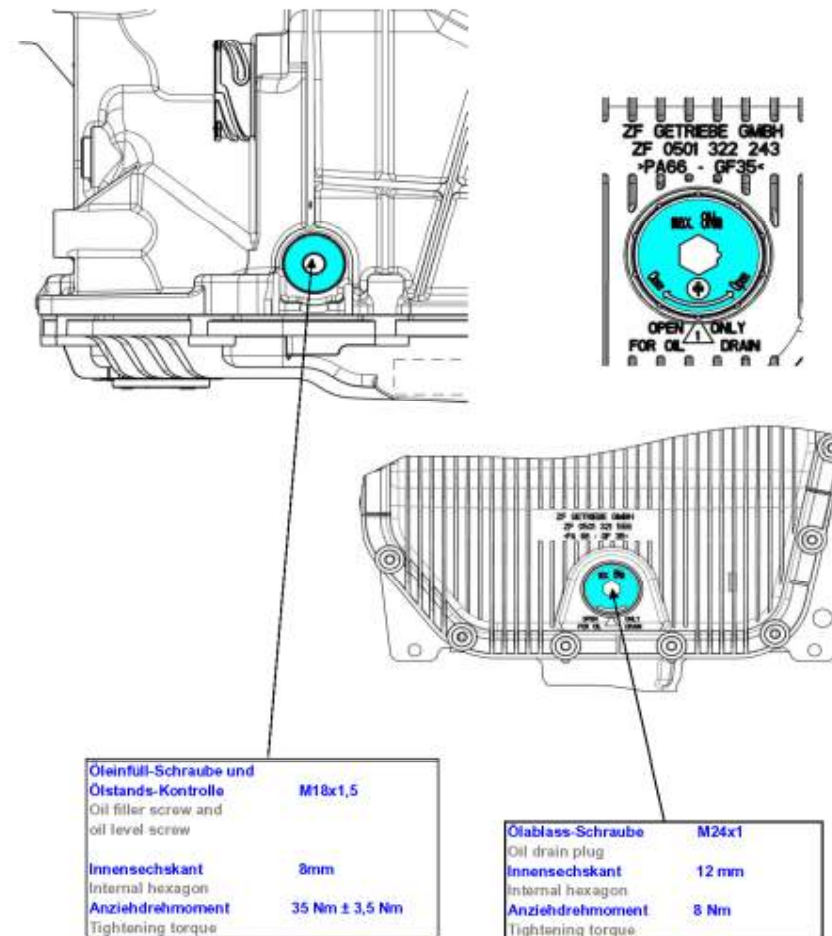



Lifetime Oil for 6-speed / 8-speed Transmissions



ZF Getriebe GmbH Kundendienst-Zentrum
Untertürkheimer Straße 4 D-66117 Saarbrücken
Phone +49(0)681-920-2243 • Fax +49(0)681-920-131-2243

Artikel-Nr. / Part-No. **AA00 601 304**



Lifetime Oil for 6-speed Transmissions



ZF Getriebe GmbH Kundendienst-Zentrum
Untertürkheimer Straße 4 D-66117 Saarbrücken
Phone +49(0)681-920-2243 • Fax +49(0)681-920-131-2243

Artikel-Nr. / Part-No. **S671.090.255**



Lifetime Oil for 6-speed Transmissions



ZF Getriebe GmbH Kundendienst-Zentrum
Untertürkheimer Straße 4 D-66117 Saarbrücken
Phone +49(0)681-920-2243 • Fax +49(0)681-920-131-2243

Artikel-Nr. / Part-No. **S671.090.281**



Thank you very much for your attention!

